



RA10

RA10 S

Reservdelar

Spare parts

Ersatzteile

Pieces de rechange

Piezas de repuesto

Ricambi

Peças sobresselente

No.	Pos.	Description	No.	Pos.	Description
501 04 97-01	A	SHAFT			
502 44 66-01	A	PARALLEL KEY			
503 20 02-16	C	SCREW			
503 20 07-12	C	SCREW			
503 20 30-11	B	SCREW			
503 22 66-01	B	NUT			
503 23 01-04	A	WASHER STEEL			
503 25 21-01	AC	BALL BEARING			
505 27 06-09	A	GASKET			
506 07 08-01	C	SPACING SLEEVE			
506 22 66-11	A	RAIL FIXTURE			
506 22 66-12	A	RAIL FIXTURE			
506 22 67-03	A	RAIL ATTACHMENT			
506 22 67-04	A	RAIL ATTACHMENT			
506 22 68-01	A	SHAFT			
506 22 69-03	A	LOCKING HANDLE			
506 22 69-04	A	LOCKING HANDLE			
506 22 70-01	A	SPACER TUBE			
506 22 70-02	A	SPACER TUBE			
506 22 72-01	A	SHAFT			
506 22 75-01	C	SLEEVE			
506 22 76-04	A	LOCKING HANDLE			
506 22 77-02	A	DRAW SPRING			
506 22 78-01	A	NEEDLE BEARING			
506 23 63-01	A	FLAT BAR			
506 26 63-02	D	LINING			
506 26 66-01	B	BELT TENSIONER ASSY			
506 26 68-01	B	COMPRESSION SPRING			
506 27 92-03	B	BELT GUARD			
506 27 92-04	B	BELT GUARD			
506 28 84-01	C	SCREEN PATTERN FLANG			
506 34 05-24	D	WHEEL GUARD ASSY			
506 34 05-26	D	WHEEL GUARD ASSY			
506 34 46-02	D	HANDLE			
506 35 07-63	C	SHAFT			
506 37 27-38	D	BELT			
506 38 54-01	A	KNOB			
544 39 97-01	A	SPRING			
544 88 71-01	A	LABEL			
544 88 75-01	C	BEARING HOUSING			
544 88 75-03	C	BEARING HOUSING			
544 92 34-03	A	ARM BASE ASSY			
544 92 35-05	A	ARM TOP ASSY			
723 63 70-01	A	SCREW			
725 53 31-55	D	SCREW			
732 21 16-01	A	NUT			
732 25 22-01	A	NUT			
735 31 33-10	A	CIRCLIP			

A

RA 10, RA 10S

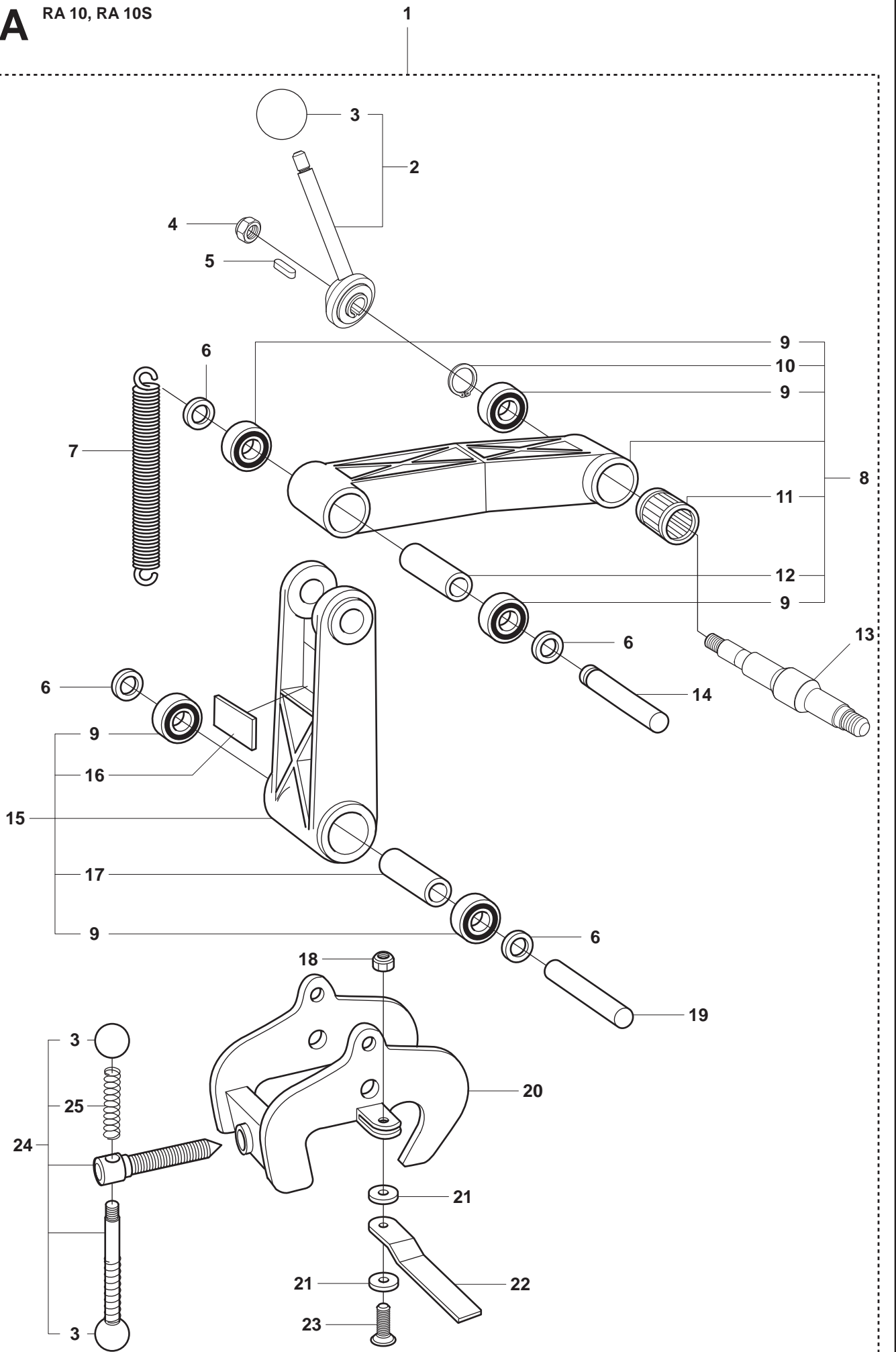

Page A**RA10, RA10 S, K1250 Rail**

Pos.	Part No.	Description	Quantity	Notes	New Part
1	506 22 66-11	RAIL FIXTURE	1	RA10. Incl. 2 - 24	New Part
1	506 22 66-12	RAIL FIXTURE	1	RA10 S. Incl. 2 - 24	New Part
2	506 22 76-04	LOCKING HANDLE	1	Incl. 3	New Part
3	506 38 54-01	KNOB	3		
4	732 25 22-01	NUT	1		
5	502 44 66-01	PARALLEL KEY	1		
6	503 23 01-04	WASHER STEEL	4		
7	506 22 77-02	DRAW SPRING	1		
8	544 92 35-05	ARM TOP ASSY	1	Incl. 9 - 12	New Part
9	503 25 21-01	BALL BEARING	5		
10	735 31 33-10	CIRCLIP	1		
11	506 22 78-01	NEEDLE BEARING	1		
12	506 22 70-01	SPACER TUBE	1		
13	501 04 97-01	SHAFT	1		New Part
14	506 22 72-01	SHAFT	1		
15	544 92 34-03	ARM BASE ASSY	1	Incl. 9, 16, 17	New Part
16	544 88 71-01	LABEL	1		
17	506 22 70-02	SPACER TUBE	1		
18	732 21 16-01	NUT	1		
19	506 22 68-01	SHAFT	1		
20	506 22 67-03	RAIL ATTACHMENT	1	RA10	
20	506 22 67-04	RAIL ATTACHMENT	1	RA10 S	
21	505 27 06-09	GASKET	2		
22	506 23 63-01	FLAT BAR	1		
23	723 63 70-01	SCREW	1		
24	506 22 69-03	LOCKING HANDLE	1	RA10. Incl. 3, 25	
24	506 22 69-04	LOCKING HANDLE	1	RA10 S. Incl. 3, 25	
25	544 39 97-01	SPRING	2		

B RA 10, RA 10S

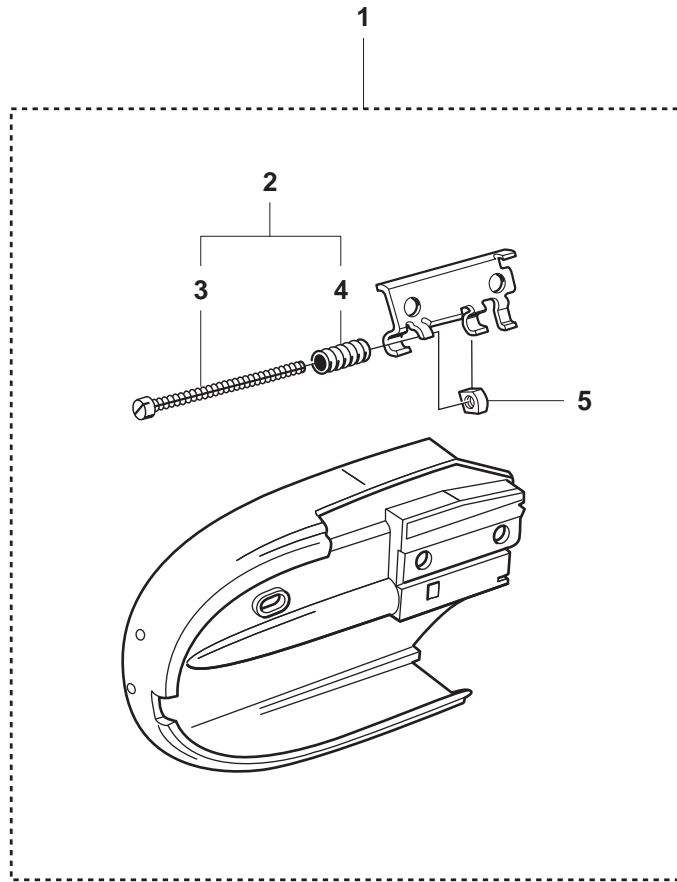

Page B**RA10, RA10 S, K1250 Rail**

Pos.	Part No.	Description	Quantity	Notes	New Part
1	506 27 92-03	BELT GUARD	1	14". Incl. 2, 5	
1	506 27 92-04	BELT GUARD	1	16". Incl. 2, 5	
2	506 26 66-01	BELT TENSIONER ASSY	1	Incl. 3, 4	
3	503 20 30-11	SCREW	1		
4	506 26 68-01	COMPRESSION SPRING	1		
5	503 22 66-01	NUT	1		

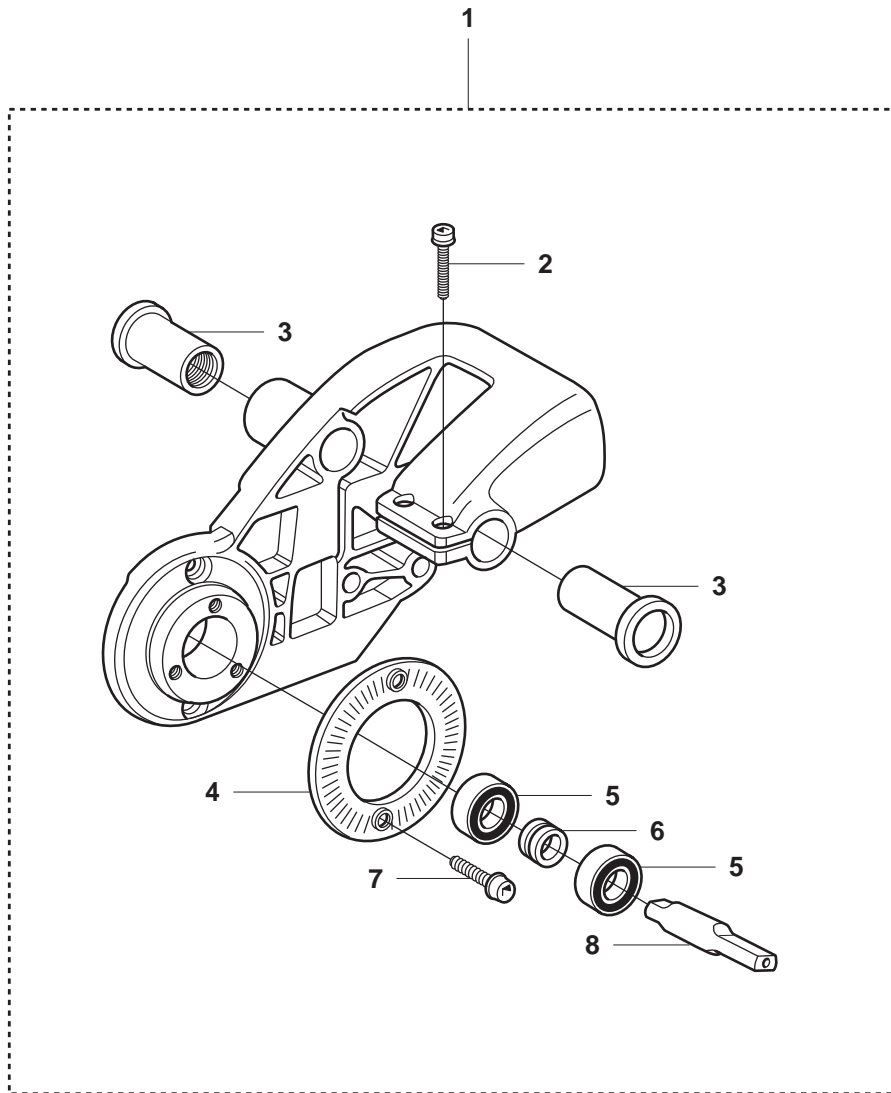

Page C**RA10, RA10 S, K1250 Rail**

Pos.	Part No.	Description	Quantity	Notes	New Part
1	544 88 75-01	BEARING HOUSING	1	14". Incl. 2 - 8	
1	544 88 75-03	BEARING HOUSING	1	16". Incl. 2 - 8	
2	503 20 02-16	SCREW	2		
3	506 22 75-01	SLEEVE	2		
4	506 28 84-01	SCREEN PATTERN FLANG	1		
5	503 25 21-01	BALL BEARING	2		
6	506 07 08-01	SPACING SLEEVE	1		
7	503 20 07-12	SCREW	2		
8	506 35 07-63	SHAFT	1		

D RA 10, RA 10S

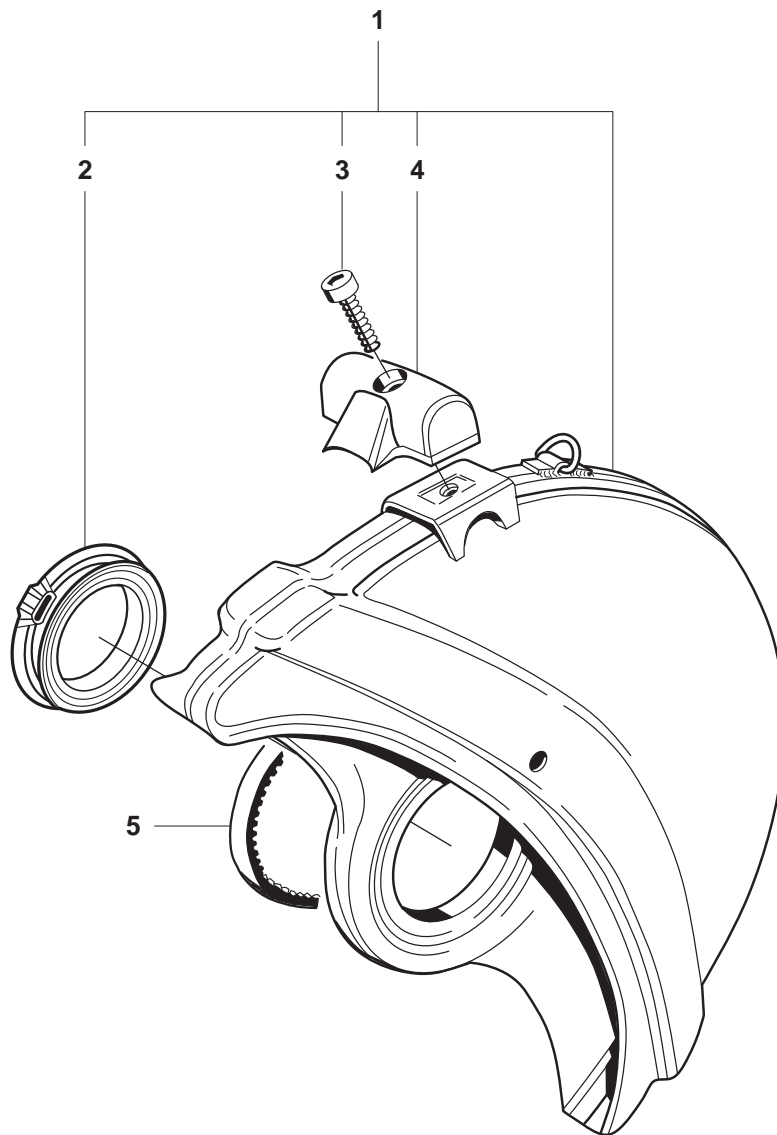

Page D**RA10, RA10 S, K1250 Rail**

Pos.	Part No.	Description	Quantity	Notes	New Part
1	506 34 05-24	WHEEL GUARD ASSY	1	14". Incl. 2, 3, 4	
1	506 34 05-26	WHEEL GUARD ASSY	1	16". Incl. 2, 3, 4	
2	506 26 63-02	LINING	1		
3	725 53 31-55	SCREW	1		
4	506 34 46-02	HANDLE	1		
5	506 37 27-38	BELT	1		

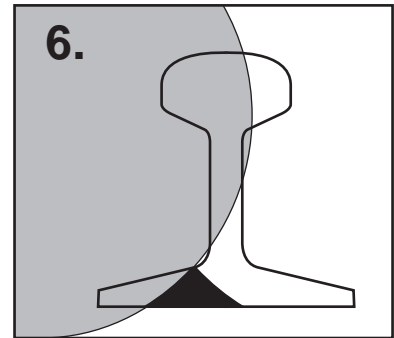
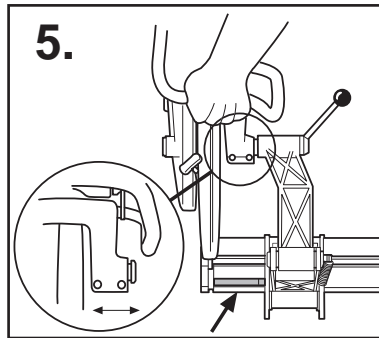
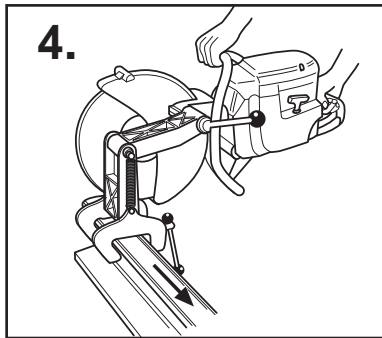
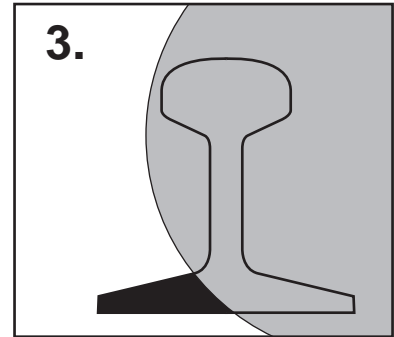
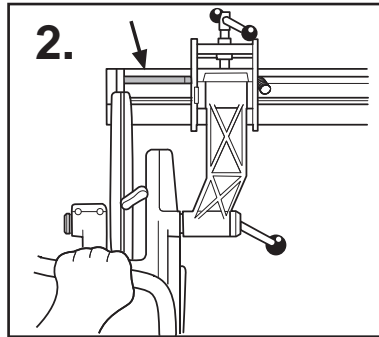
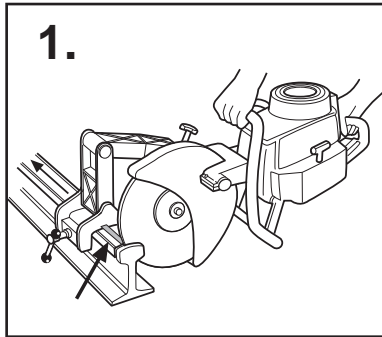

SE Instruktion för rälskapning med Partners kapmaskiner och rälsfixtur RA 10, RA 10S.

1. Spänn fast rälsfästet på rälsen och skruva fast maskinen enligt bild 1.
2. Första gången fixturen används skall indikatorvisaren kapas till korrekt längd genom att den fälls ut och kapas av med kapskivan. Detta ger rätt position vid de följande snitten.
3. Kapa rälsen enligt bild 3.
4. Lossa maskinen från fixturen och spänn fast den på andra sidan enligt bild 4.
5. Vid behov, justera den rörliga bussningen så att de två snitten överensstämmer.
6. Avsluta kapningen från den andra sidan enligt bild 6.

GB Instruction for rail cutting with Partner machines and RA 10, RA 10S fixture.

1. Attach the fixture to the rail and hook up the machine as shown in fig. 1.
2. At the very first cut, the guiding pin shall be cut to correct length. This will give the position for the following cuts.
3. Cut the rail as shown in fig. 3.
4. Loosen the machine from the fixture and place it on the opposite side of the rail.
5. If necessary, adjust the adjustable bushing so that the two cuts will meet.
6. Finish the cutting from the opposite side as shown in fig. 6.

FR Instructions pour la découpe du rail avec les decoupeuses Partner et le bras de fixation RA 10, RA 10S.

1. Attacher le bras de fixation RA10 sur le rail, puis fixer dessus la machine comme indiqué figure 1.
2. Lors de la toute première coupe, le régleur articulé doit être coupé à la longueur souhaitée. Ceci afin de servir de référence pour les coupes suivantes.
3. Couper le rail comme indiqué figure 3.
4. Détacher la machine du bras de fixation, et repositionner la sur l'autre coté du rail.
5. Au besoin, juster a la machine à l'aide de la vis de réglage, de façon à ce que les deux coupes puissent coïncider.
6. Finir la coupe de l'autre coté du rail comme indiqué figure 6.

DE Anweisung zum Trennen von Gleisen mit Partner Schienentrennschleifgeräten und der Vorrichtung RA 10, RA 10S.

1. Montieren Sie die Gleistrennvorrichtung auf dem Schienenstrang, wie in Abb. 1 gezeigt.
2. Vor dem ersten Schnitt sollte der klappbare Zeiger zur Markierung der exakten Schnittposition auf richtige Länge geprüft werden. Dies ergibt die genaue Position der nachfolgenden Schnitte.
3. Trennen Sie den Schienenstrang wie in Abb. 3 gezeigt.
4. Heben Sie das Gerät aus der Trennvorrichtung und bereiten den Schnitt von der anderen Seite des Schienenstranges vor.
5. Bei Bedarf Stellen Sie den klappbaren Zeiger so ein, daß sich die beiden Schnitte treffen.
6. Beenden Sie den Trennvorgang der gegenüberliegenden Seite, wie in Abb. 6 gezeigt.

Instrucciones para cortar rail con las máquinas Partner y RA 10, RA 10S figuras.

- ES**
1. Fijar el brazo soporte al rail y conectar la máquina según figura 1.
 2. El en primer corte se cortara la guía a la longitud correcta.
 3. Cortar el rail según figura 3.
 4. Soltar la máquina del brazo y colocarla en la parte opuesta del rail.
 5. Si es necesario, ajustar el casquillo de la cortadora para hacer coincidir los cortes (según figura 1).
 6. Finalizar el corte del lado contrario (figura 6).