

**00700 SURFACING
 GUIDE GRINDER**

The Matweld Surfacing Guide is a rugged but lightweight grinding attachment designed specifically for grinding the top of the rail. It is excellent for the finish grinding of field welds or rail end repairs. The extended guard offers excellent protection for the operator.

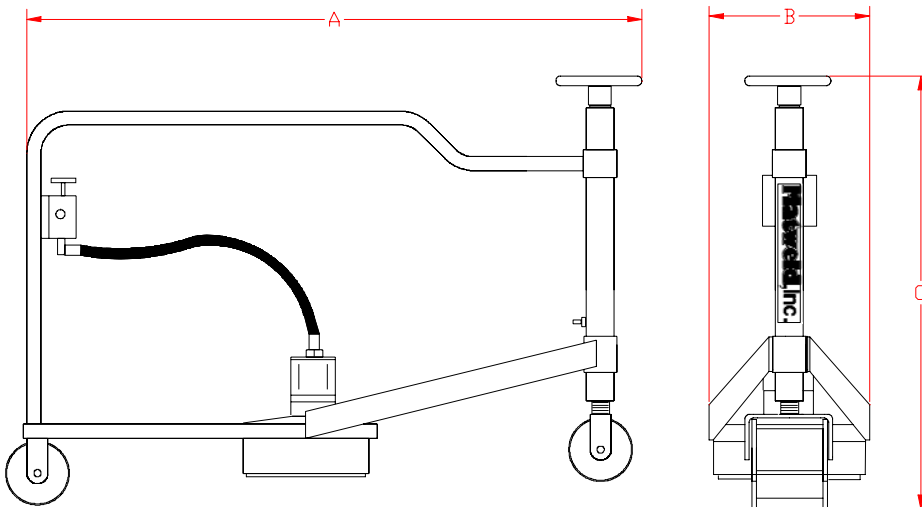

FLOW	PRESSURE	RPM	DIMENSIONS	WEIGHT
10 gpm (38 lpm)	2000 psi (140 bar)	3900	A - 39" (991mm) B - 12" (305mm) C - 26" (660mm)	75 lbs (34 kg)

ACCESSORIES:

- 00799 - 8" x 2" x 4" PLATE MOUNTED CUP STONE
- 00733-KIT - TYPE 6 STONE ADAPTOR
- 00797 - TYPE 6 STONE 8" x 2" x 1 1/2"

MATWELD, INC.

PHONE:(270) 444-0085

FAX:(270) 443-6180

Matweld reserves the right to change parts, features, or specifications without notice.

GENERAL SAFETY PRECAUTIONS:

TOOL OPERATORS AND MAINTENANCE PERSONNEL MUST ALWAYS COMPLY WITH THE SAFETY PRECAUTIONS GIVEN IN THIS MANUAL, AND WITH ALL STICKERS AND TAGS ATTACHED TO THE TOOL AND HOSE. ALL SAFETY PRECAUTIONS ARE GIVEN FOR YOUR SAFETY. READ TO UNDERSTAND AND FOLLOW ALL SAFETY, MAINTENANCE AND OPERATION INSTRUCTIONS BEFORE YOU USE OR MAINTAIN THE TOOL. REVIEW THE MANUAL DAILY BEFORE USING THE TOOL. IN ADDITION, FOLLOW ALL SAFETY GUIDELINES GIVEN TO YOU BY YOUR SUPERVISOR. DO NOT USE THE TOOL IF YOU HAVE ANY QUESTIONS ABOUT THE OPERATION, SAFETY OR MAINTENANCE OF THIS TOOL. FAILURE TO FOLLOW THESE INSTRUCTIONS CAN RESULT IN PERSONAL INJURY OR EQUIPMENT DAMAGE.

MATWELD HAS NO CONTROL OVER TOOL USE OR OPERATION ONCE IT LEAVES THE MATWELD PLANT. MATWELD HAS NO CONTROL OVER OPERATOR OR MAINTAINER SELECTION. THE CUSTOMER MUST ASSUME RESPONSIBILITY FOR THE TOOL'S SUITABILITY FOR A PARTICULAR FUNCTION, FOR ANYONE USING THE TOOL OR MAINTAINING THE TOOL REGARDING THEIR FITNESS TO USE THE TOOL OR REPAIR THE TOOL, UNDERSTANDING OF THE OPERATION AND SAFETY AND MAINTENANCE MANUAL, INTELLIGENCE TO USE GOOD JUDGMENT IS NECESSARY TO WORK SAFELY AND EFFICIENTLY WITHOUT ENDANGERING THEMSELVES OR BYSTANDERS IN THE WORK AREA.

- DO NOT OPERATE THE TOOL UNTIL YOU HAVE BEEN THOROUGHLY AND PROPERLY TRAINED OR UNDER THE SUPERVISION OF AN INSTRUCTOR.
- CHECK POWER SOURCE DAILY TO DETERMINE IF CORRECT FLOW AND PRESSURE ARE AVAILABLE. NEVER EXCEED FLOWS OR PRESSURES FOR THE TOOL BEING USED. PERSONAL INJURY OR DAMAGE TO THE TOOL CAN RESULT.
- OPERATORS MUST CLEAR THE WORK AREA OF NON-ESSENTIAL PERSONNEL. FLYING DEBRIS CAN CAUSE SERIOUS INJURY.
- THE OPERATOR MUST BE FAMILIAR WITH ALL PROHIBITED WORK AREAS SUCH AS UNSAFE GRADES, POOR FOOTING AREAS AND OVERHEAD HAZARDS.
- MAINTAIN BALANCE AND PROPER FOOTING AT ALL TIMES. NEVER OVERREACH TO THE EXTENT THAT A BROKEN PART OR SUDDEN MOVEMENT OF THE TOOL CAN CAUSE YOU TO LOSE YOUR BALANCE AND FALL, OR CAUSE INJURY TO YOUR SELF OR SOMEONE ELSE.

- WHEN WORKING NEAR ELECTRICAL CONDUCTORS, ALWAYS ASSUME THAT THE CONDUCTORS ARE ENERGIZED AND THAT HOSES AND CLOTHING CAN CONDUCT HARMFUL ELECTRICITY. USE HOSES LABELED AND CERTIFIED AS NON-CONDUCTIVE.
- DO NOT OPERATE THE TOOL AT EXCESSIVE FLUID TEMPERATURES. OPERATOR DISCOMFORT AND POTENTIAL BURNS CAN RESULT AT HIGH OIL TEMPERATURES.
- NEVER WEAR LOOSE CLOTHING THAT CAN GET ENTANGLED IN THE WORKING PARTS OF THE TOOLS OR BE CARELESS WITH HANDS, FEET OR OTHER BODY PARTS AROUND THE WORKING PARTS OF THE TOOLS. HYDRAULIC TOOLS EXERT HIGH TORQUE AND FORCE AND CAN CAUSE SERIOUS INJURY OR DEATH IF IMPROPERLY USED.
- TO AVOID PERSONAL INJURY OR EQUIPMENT DAMAGE, ALL TOOL REPAIR, MAINTENANCE OR SERVICE MUST ONLY BE PERFORMED BY AUTHORIZED AND PROPERLY TRAINED PERSONNEL.
- ALWAYS WEAR SAFETY EQUIPMENT SUCH AS OIL INJECTION RESISTANT WORK GLOVES, SAFETY GLASSES, SAFETY BOOTS, EAR PROTECTION AND OTHER SAFETY APPAREL DICTATED BY YOUR SUPERVISOR APPLICABLE FOR THE JOB YOU ARE DOING AND THE TOOL YOU ARE USING.
- DO NOT CLEAN, INSPECT, OR REPAIR THE TOOL WHILE CONNECTED TO THE POWER SOURCE. ACCIDENTAL ENGAGEMENT OF THE TOOL CAN CAUSE SERIOUS PERSONAL INJURY.
- OIL INJECTION HAZARD EXISTS WITH THIS TOOL. OIL INJECTION IS A CONDITION WHERE HYDRAULIC OIL IS INJECTED UNDER THE SKIN FROM PRESSURE IN THE LINE. ALWAYS WEAR GLOVES AND REPAIR ANY LEAKS IMMEDIATELY. NEVER CARRY A TOOL BY THE HOSES.
- DO NOT USE DAMAGED EQUIPMENT. IMMEDIATELY REPLACE ANY DAMAGED HOSES, FITTINGS, OR OTHER COMPONENTS SHOWING WIRE BRAID, NICKS, CUTS, DAMAGE OR ABRASIONS. FAILURE TO DO SO MAY RESULT IN EQUIPMENT DAMAGE AND / OR PERSONAL INJURY OR DEATH.
- CLEAN UP ANY OIL OR FLUID SPILLS IMMEDIATELY.

HAVE SUPERVISOR ADD ADDITIONAL PRECAUTIONS RELATING TO THE SPECIFIC WORK AREA AND LOCAL SAFETY REGULATIONS BELOW:

- *
- *
- *
- *
- *
- *
- *
- *
- *
- *
- *
- *
- *
- *
- *
- *
- *
- *
- *
- *
- *

SAFETY PRECAUTIONS:

1. **ALWAYS** WEAR PROTECTIVE EQUIPMENT SUCH AS GLOVES, SAFETY GLASSES, EAR PROTECTION AND SAFETY SHOES.
2. DO NOT WEAR CLOTHING WHICH MAY BECOME ENTANGLED IN THE TOOL.
3. **ALWAYS** KEEP WORK AREA FREE OF TOOLS OR ANY OTHER OBJECTS WHICH MAY IMPAIR SOUND FOOTING.
4. **CAUTION** OIL INJECTION HAZARD EXISTS WITH THIS TOOL. OIL INJECTION IS A CONDITION WHERE THE HYDRAULIC OIL IS FORCED UNDER THE SKIN THROUGH PRESSURE IN THE LINE. ALWAYS WEAR GLOVES, DO NOT CARRY THE TOOL BY HYDRAULIC HOSES, AND REPAIR LEAKS IMMEDIATELY..
5. **NEVER** CHANGE STONES WITH THE POWER SOURCE VALVE(S) IN THE “**ON**” POSITION, TURN THE POWER SOURCE “**OFF**”.
6. **NEVER** ATTEMPT TO CARRY THE GRINDER WITH THE POWER SOURCE IN THE “**ON**” POSITION, TURN THE POWER SOURCE “**OFF**”.
7. **NEVER** TOUCH OR TRY TO STOP A MOVING STONE.
8. **ALWAYS** CHECK THE WORK AREA FOR ANY TRASH WHICH MAY IGNITE FROM SPARKS.
9. **ALWAYS** CHECK THE AREA FOR SMOLDERING TIES OR TRASH BEFORE LEAVING THE SITE.
10. WHEN CHANGING STONES, FOLLOW ALL GRINDING STONE MANUFACTURERS INSTRUCTIONS FOR SAFETY AND OPERATION. USE ONLY STONES THAT COMPLY WITH ANSI STANDARDS. BEFORE USING, RUN NEW GRINDING STONE FOR ONE MINUTE AT FULL SPEED TO CHECK FOR DEFECTS OR VIBRATION.
11. MOST HYDRAULIC OILS HAVE A FLASH POINT OF APPROXIMATELY 500 DEGREES (F). MAKE SURE HOSES ARE COMPLETELY CLEAR OF SPARKS AND HOT DEBRIS. HAVE ANOTHER PERSON STAND CLOSE TO HYDRAULIC POWER SOURCE CONTROLS TO OBSERVE OPERATION AND FOR EMERGENCY SHUTDOWN IF NECESSARY.

00700 / 02700 RAIL SURFACING GUIDE

FLOW:	10 GPM (38 LPM) (<u>MODEL 00700</u>)
PRESSURE:	2000 PSI (140 BAR) (<u>MODEL 00700</u>)
MAX BACK PRESSURE:	250 PSI (17 BAR) (<u>MODEL 00700</u>)
RPM:	3900 (<u>MODEL 00700</u>)

OPERATION (MODEL 00700):

1. WITH THE TOOL TURNED “**OFF**”, PLACE TOOL ON THE RAIL CAREFULLY AND ADJUST THE STONE CLEARANCE BY TURNING THE HAND WHEEL COUNTERCLOCKWISE TO RAISE THE STONE.
2. WITH THE POWER SOURCE IN THE “OFF” POSITION, CONNECT THE HOSES. DO NOT DRAG THE SERVICE HOSE BY PULLING WITH THE TOOL. LOOP THE SERVICE HOSE IN THE WORK AREA IN SUCH A WAY TO RELIEVE STRESS ON THE HOSE AND QUICK DISCONNECT FITTINGS WHILE WORKING. BE AWARE OF HOSE LOCATION AT ALL TIMES.
3. CONNECT THE TOOL TO THE POWER SOURCE.
4. TURN THE POWER SOURCE ON TO SUPPLY 10 GPM TO TOOL.
5. TURN THE HAND WHEEL **CLOCKWISE** TO LOWER THE STONE TO BEGIN THE GRINDING OPERATION.
6. KEEP THE TOOL MOVING TO PREVENT **BURNING** OR **OVER GRINDING** THE RAIL.

OPERATION (MODEL 02700):

1. WITH THE POWER SOURCE TURNED “**OFF**”, PLACE IT ON THE RAIL CAREFULLY AND ADJUST THE STONE CLEARANCE BY TURNING THE HAND WHEEL COUNTERCLOCKWISE TO RAISE THE STONE.
2. CONNECT CABLE DRIVE TO THE TOOL BEFORE TURNING THE POWER SOURCE “**ON**”. BE AWARE OF CABLE LOCATION AT ALL TIMES.
3. START THE TOOL AND TURN THE HAND WHEEL **CLOCKWISE** TO LOWER THE STONE TO BEGIN THE GRINDING OPERATION.
4. KEEP THE TOOL MOVING TO PREVENT **BURNING** OR **OVER GRINDING** THE RAIL.

00700 / 02700 RAIL SURFACING GUIDE

MAINTENANCE:

1. CHECK TOOL **DAILY** FOR PROPER OPERATION, LEAKS, OR DAMAGE.
2. INSPECT HOSES **DAILY**. REPLACE CUT, BURNED, OR OTHERWISE DAMAGED HOSES.
3. KEEP QUICK DISCONNECT COUPLERS **CLEAN AND LUBRICATED**.
4. USE HYDRAULIC FLUIDS THAT COMPLY WITH HTMA SPECIFICATION 5.7, THE HYDRAULIC FLUID SHOULD HAVE A VISCOSITY BETWEEN 100 AND 400 SSU (20-82 CENTISTOKES) AT THE MAXIMUM AND MINIMUM EXPECTED OPERATING TEMPERATURES. PETROLEUM BASED HYDRAULIC FLUIDS WITH ANTI-WEAR PROPERTIES AND A VISCOSITY INDEX OF OVER 140 WORK FOR A WIDE RANGE OF OPERATING CONDITIONS.

THE FOLLOWING OILS MEET HTMA SPECIFICATION 5.7:

AMOCO RYKON MV	CITGO A/W ALL TEMP
SUNVIS 706	MOBIL D.T.E. 13
CHEVRON EP-MV	TEXACO "RANDO" HDAZ

OTHER FLUIDS THAT MEET OR EXCEED THIS SPECIFICATION CAN BE USED.

*SEE **COLD WEATHER OPERATION** HYDRAULIC OIL NOTE.

5. HAVE TOOL INSPECTED, AT LEAST ANNUALLY, BY A MATWELD OR MATWELD QUALIFIED SERVICE REPRESENTATIVE TO DETERMINE IF TOOL IS IN NEED OF SAFETY CHANGES OR WORN PART REPLACEMENT.
6. CONTACT MATWELD ON A PERIODIC BASIS, AT LEAST ANNUALLY, FOR SERVICE BULLETINS, SAFETY NOTICES, OR OTHER IMPORTANT INFORMATION PERTAINING TO THIS TOOL.
7. PERIODICALLY GREASE HEIGHT ADJUSTMENT SHAFT ASSEMBLY AND DRIVE SHAFT BEARING.
8. PERIODICALLY LUBRICATE AND CLEAN THE COUPLER ASSEMBLY AND SPLINE ON THE **02700** GRINDER.

00700 / 02700 RAIL SURFACING GUIDE

CHANGING THE GRINDING STONE:

- 1.) TURN THE POWER SOURCE “**OFF**” AND **DISCONNECT** HOSES OR CABLE FROM THE TOOL, LAY THE TOOL ON ITS SIDE.
- 2.) ROTATE THE STONE SLOWLY BY HAND WHILE **DEPRESSING** THE SHAFT LOCKING PIN (LOCATED ON THE SIDE OF THE DRIVE PLATE CASTING).

PLATE MOUNTED CUPSTONE:

- 3.) WHEN THE PIN ENGAGES, LOCKING THE SHAFT, REMOVE THE 4 BOLTS HOLDING THE STONE ON AND REPLACE WITH A NEW STONE. **DO NOT OVERTORQUE** THE BOLTS.

TYPE 6 STONES:

- 4.) WHEN THE PIN ENGAGES, USE A 3/8” HEX KEY WRENCH TO REMOVE RETAINER NUT AND STONE. INSTALL NEW GRINDING STONE AND TIGHTEN RETAINER NUT. **DO NOT OVERTIGHTEN RETAINER NUT.**
- ***REFER TO MANUFACTURER’S SPECIFICATIONS FOR TORQUE SETTINGS ON STONE ATTACHMENT***

00700 / 02700 RAIL SURFACING GUIDE

GENERAL NOTES:

REVIEW OF HYDRAULIC PRINCIPLES

A. TOOL CIRCUIT

1. HYDRAULIC FORMULAS:

$$\text{GPM} = \frac{\text{CID} \times \text{RPM}}{231} \qquad \text{HP} = \frac{\text{GPM} \times \text{PSI}}{1714 (.85)}$$

Example: HP required to deliver 10 GPM at 1500 PSI.

$$\frac{10 \text{ GPM} \times 1500 \text{ PSI}}{1456.9} = \frac{15000}{1456.9} = 10.3 \text{ HP}$$

(subtract back pressure for tool HP)

Estimated HP delivered by pump or used by tool.

GPM	PSI	500	1,000	1,500	2,000	2,500	3,000
3		1.03	2.06	3.09	4.12	5.15	6.18
5		1.72	3.43	5.15	6.86	8.58	10.30
10		3.43	6.86	10.3	13.70	17.20	20.60
15		5.15	10.30	15.40	20.60	25.70	30.90

2. BACK PRESSURE

BACK PRESSURE MEASURED AT THE TOOL RETURN PORT MUST NOT EXCEED THE MANUFACTURERS BACK PRESSURE RATING. MOST MANUFACTURERS LIST THE MAXIMUM BACK PRESSURE FOR THEIR HYDRAULIC TOOLS AT 250 PSI. BACK PRESSURE MEASURED ON THE RETURN SIDE OF THE TOOL IS THE FORCE REQUIRED TO GET THE OIL BACK TO THE TANK. IN ALMOST ALL CASES THE LOWER THE BACK PRESSURE THE BETTER THE TOOL PERFORMANCE. FIRST, THE BACK PRESSURE IS SUBTRACTED FROM THE MAXIMUM TOOL PRESSURE TO ARRIVE AT A MAXIMUM TOOL OPERATING PRESSURE. FOR EXAMPLE, TOOLS WITH 2000 PSI OPERATING PRESSURE ARE INSTALLED ON A SYSTEM WITH 250 PSI BACK PRESSURE. THIS LEAVES 1750 PSI AS A MAXIMUM TOOL PRESSURE. IMAGINE A SYSTEM WITH 500 PSI BACK PRESSURE. 2000 MINUS 500 PSI BACK PRESSURE LEAVES ONLY 1500 PSI FOR THE TOOL. SECOND, TOOLS ARE DESIGNED FOR PRESSURE TO BUILD ON THE PRESSURE SIDE OF THE TOOL. IF TOO MUCH PRESSURE BUILDS ON THE RETURN SIDE, NOT ONLY IS PERFORMANCE EFFECTED, BUT SEALS MAY BLOW. THIS IS WHY IT IS VERY IMPORTANT TO DIRECT THE FLOW INTO THE TOOL CORRECTLY. REVERSING THE HOSES TO TEST MAY RESULT IN BLOWN SEALS, DAMAGE TO THE TOOL, AND PERSONAL INJURY.

**00700 SURFACING GUIDE
 FRAME ASSEMBLY
 REV. 2 3/26/03**

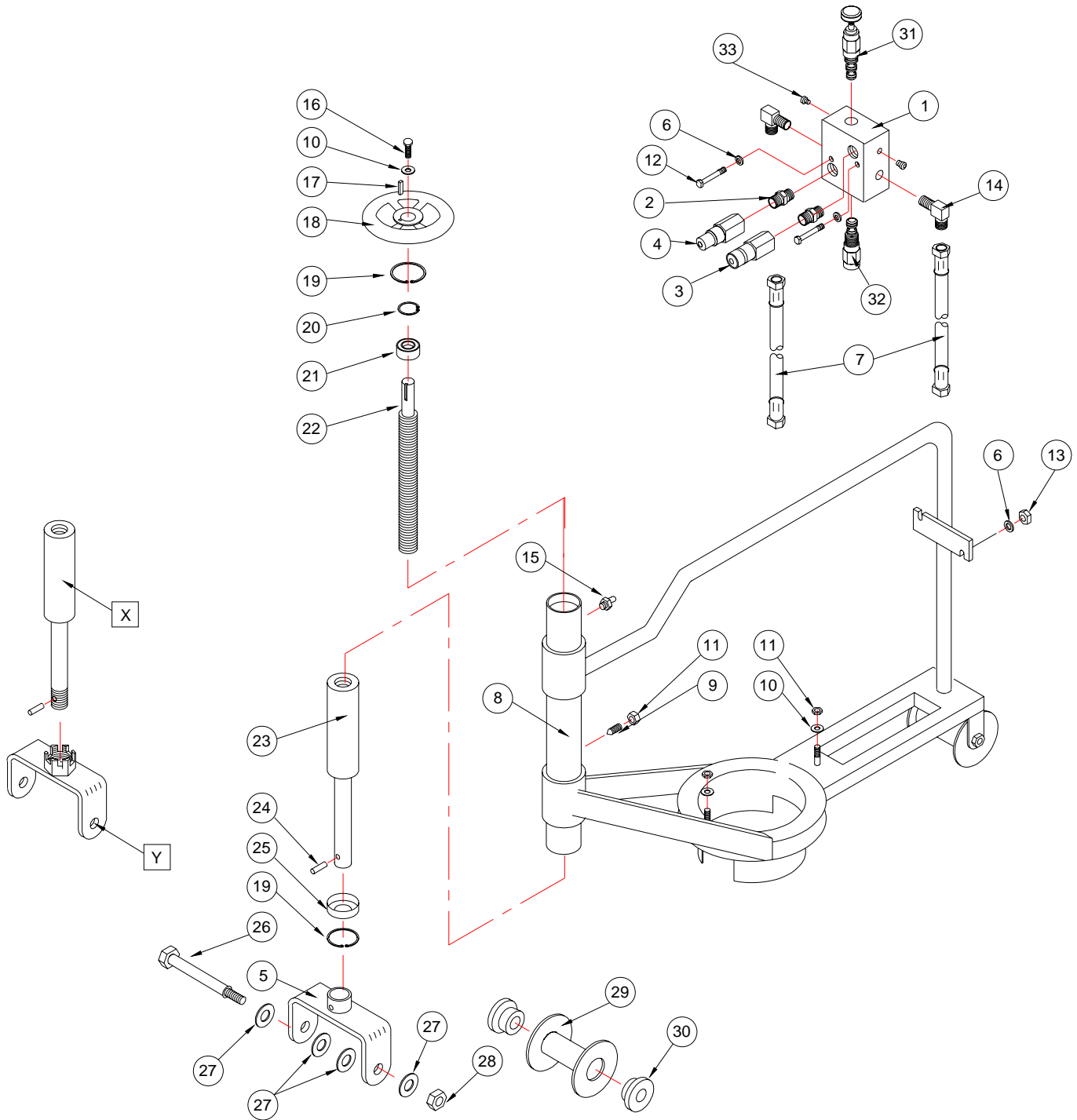

EARLY MODEL GRINDERS USE 711 THREADED YOKE AND 708 THREADED HEIGHT ADJUSTMENT SHAFT

MATWELD, INC.

PHONE:(270) 444-0085

FAX:(270) 443-6180

Matweld reserves the right to change parts, features, or specifications without notice.

00700 SURFACING GUIDE
FRAME ASSEMBLY
REV. 2 3/26/03

ITEM NO.	PART NO.	DESCRIPTION	QTY.
1	00795	VALVE BODY	1
2	69-08-08	1/2 NPT HEX NIPPLE	2
3	00145	QUICK DISCONNECT COUPLER	1
4	00146	QUICK DISCONNECT NIPPLE	1
5	00711A	FRONT YOKE	1
6	A2190	1/4 SAE FLAT WASHER	4
7	00450	MOTOR HOSES	2
8	00701	GRINDER FRAME	1
9	A5629	CONE POINT SET SCREW	1
10	A2163	3/8 USS FLAT WASHER	3
11	A2050	3/8-16 NYLOCK NUT	3
12	A1009	1/4-20 X 2 1/4 HEX HEAD BOLT	2
13	A2046	1/4-20 NYLOCK NUT	2
14	405-08-08	1/2 MJIC x 1/2 NPT 90 ELBOW	2
15	GF-101	GREASE FITTING	1
16	A1041	3/8-16 x 3/4 HEX HEAD BOLT	1
17	00704	SQUARE KEY	1
18	00703	HAND WHEEL	1
19	00705	1 5/8 INTERNAL RETAINING RING	2
20	00706	3/4 EXTERNAL RETAINING RING	1
21	00713	BEARING HEIGHT ADJUSTMENT	1
22	00707	HEIGHT ADJUSTMENT SCREW	1
23	00708	HEIGHT ADJUSTMENT SHAFT	1
24	A6101	DIA. 1/4 x 1/2 SPRING PIN	1
25	00710	SEAL HEIGHT ADJUSTMENT SHAFT	1
26	A1098	1/2-13 x 6 HEX HEAD BOLT	2
27	A2194	1/2 SAE FLAT WASHER	8
28	A2054	1/2-13 NYLOCK NUT	2
29	00108	RAIL WHEEL	2
30	00109	RAIL WHEEL BEARING	4
31	00137	VALVE CARTRIDGE CONTROL	1
32	00796	FLOW CONTROL VALVE	1
33	231P-04	#4 O-RING PLUG	2

* PARTS USED FOR BOTH THE 00700 AND 02700 SUFACING GUIDE GRINDERS

ACCESSORIES

0733-KIT TYPE 6 STONE ADAPTER
00798 TYPE 6 STONE 8" x 2" x 4"
00799 PLATE MOUNTED STONE 8" x 2" x 4"

MATWELD, INC.

PHONE:(270) 444-0085

FAX:(270) 443-6180

Matweld reserves the right to change parts, features, or specifications without notice.

**00720
HEAD ASSEMBLY
REV. 1 5/04**

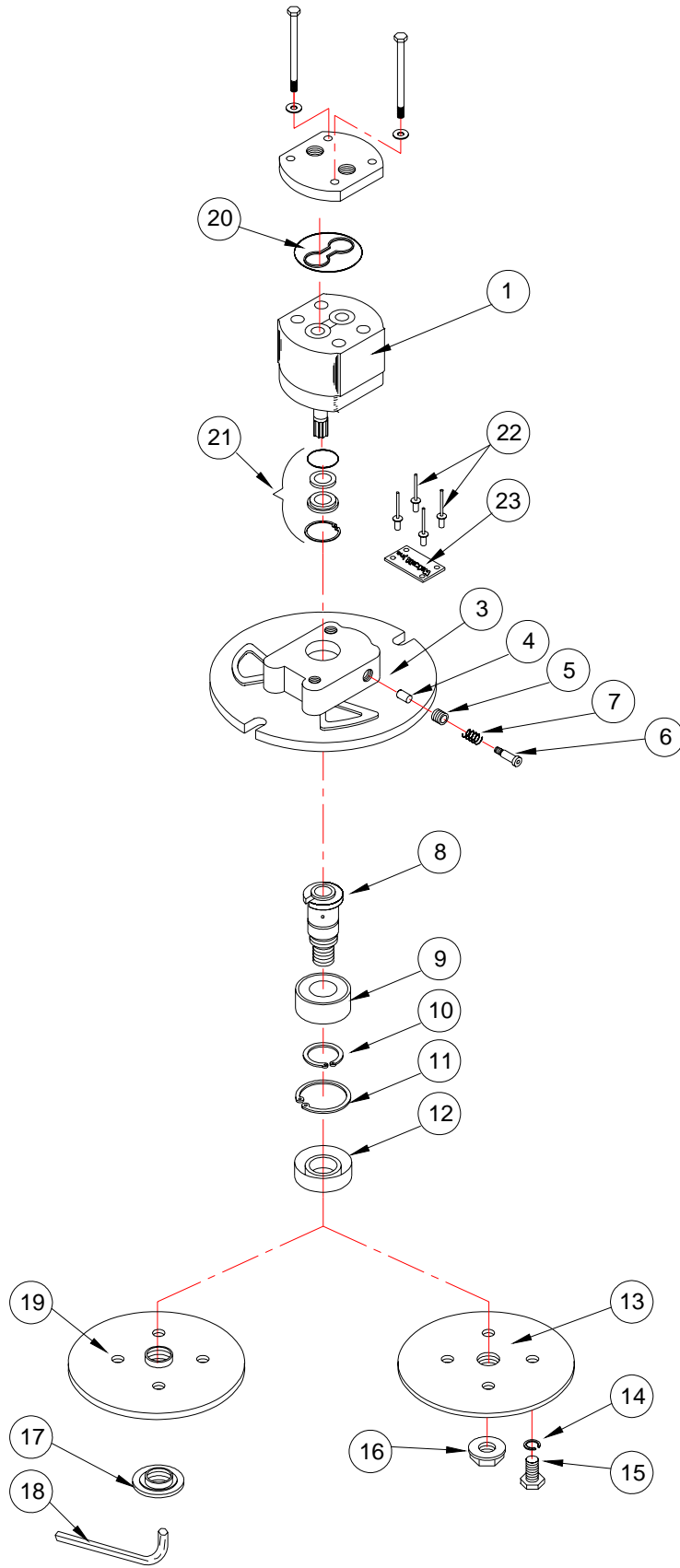

TYPE 6 STONE ADAPTER

PLATE MOUNTED STONE ADAPTER

MATWELD, INC.

PHONE:(270) 444-0085

FAX:(270) 443-6180

Matweld reserves the right to change parts, features, or specifications without notice.

00720
HEAD ASSEMBLY
REV. 1 5/04

ITEM NO.	PART NO.	DESCRIPTION	QTY.
1	00410B	TOP PORT MOTOR	1
2		OMIT	
3	00702	DRIVE PLATE	1
4	00412	LOCKING PIN	1
5	00415	PLUG	1
6	A6910	DIA. 1/4 x 1 SHOULDER BOLT	1
7	00413	#6 SPRING	1
8	048001	DRIVE SHAFT	1
9	046003	BEARING	1
10	046005	RETAINING RING	1
11	00403	INTERNAL RETAINING RING	1
12	046004	SEAL	1
13	00604	STONE ADAPTER PLATE	1
14	A3813	1/2 LOCK WASHER	4
15	A1081	1/2-20 x 3/4 HEX HEAD BOLT	4
16	A2063	5/8-11 FLANGE NUT	1
(17)	00734	FLANGE RETAINER TYPE 6	1
(18)	02718	3/8 HEX WRENCH	1
(19)	00733	STONE FLANGE TYPE 6	1
20	02599	INTERNAL SEAL KIT	1
21	02598	SHAFT SEAL KIT	1
22	SSB4-6S	1/8 x 3/8 SS RIVET	4
23	SERIAL TAG	SERIAL NUMBER TAG	1

** SOLD IN KIT FORM ONLY
 () SOLD IN 0733-KIT

ACCESSORIES/ASSEMBLIES

- 00720 HEAD ASSEMBLY WITH MOTOR
- 00725 HEAD ASSEMBLY WITHOUT MOTOR
- 0733-KIT TYPE 6 STONE ADAPTER
- 00798 TYPE 6 STONE 8" x 2" x 4"
- 00799 PLATE MOUNTED STONE 8" x 2" x 4"

**02700 SURFACING GUIDE
FRAME ASSEMBLY**

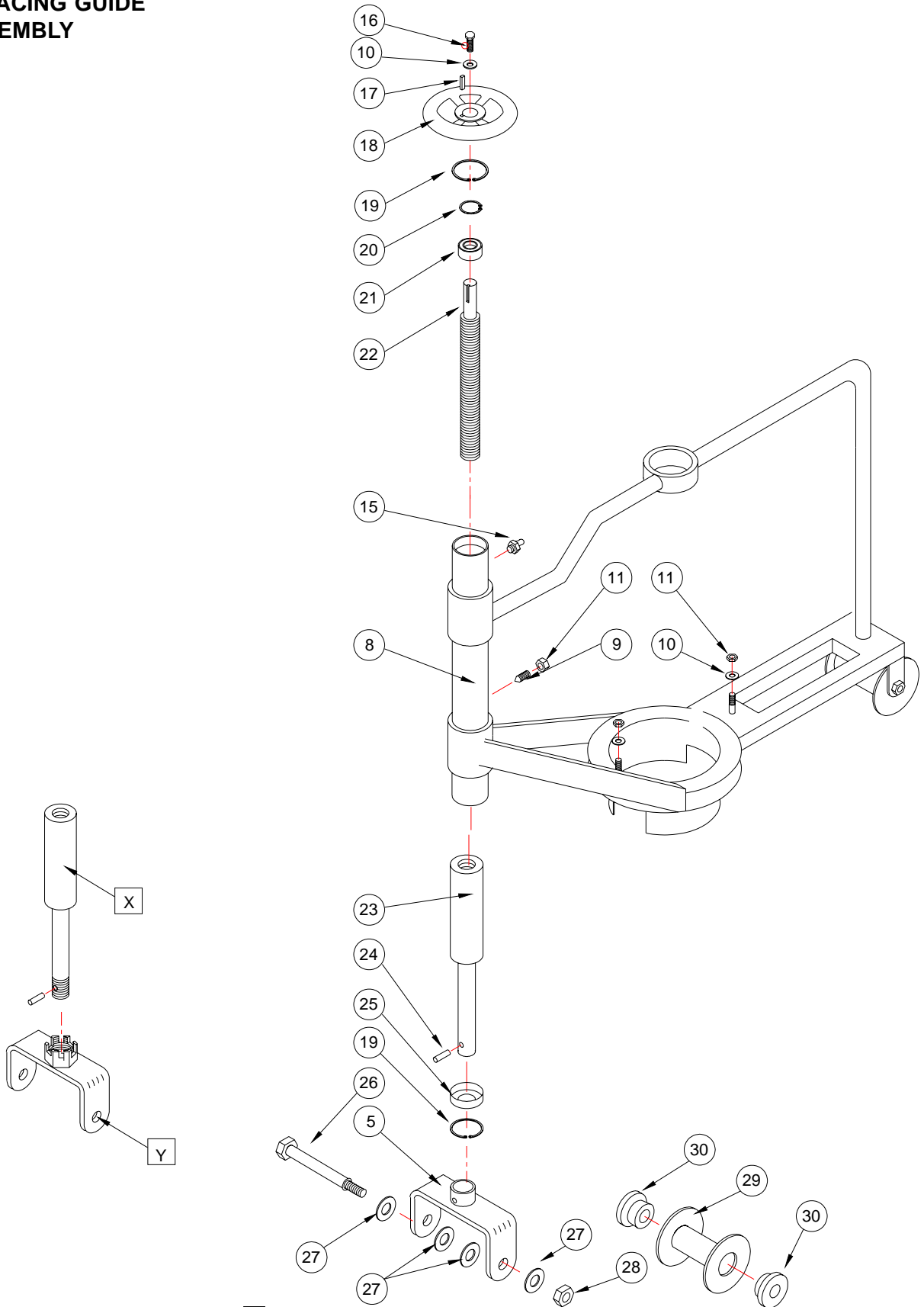

EARLY MODEL GRINDERS USE 711
 THREADED YOKE AND 708 THREADED
 HEIGHT ADJUSTMENT SHAFT

MATWELD, INC.

PHONE:(270) 444-0085

FAX:(270) 443-6180

Matweld reserves the right to change parts, features, or specifications without notice.

**02700 SURFACING GUIDE
FRAME ASSEMBLY**

ITEM NO.	PART NO.	DESCRIPTION	QTY.
5	00711A	FRONT YOKE	1
8	02707	GRINDER FRAME	1
9	A5629	CONE POINT SET SCREW	1
10	A2163	3/8 USS FLAT WASHER	3
11	A2050	3/8-16 NYLOCK NUT	3
15	GF-101	GREASE FITTING	1
16	A1041	3/8-16 X 3/4 HEX HEAD BOLT	1
17	00704	SQUARE KEY	1
18	00703	HAND WHEEL	1
19	00705	1 5/8 INTERNAL RETAINING RING	2
20	00706	3/4 EXTERNAL RETAINING RING	1
21	00713	BEARING HEIGHT ADJUSTMENT	1
22	00707	HEIGHT ADJUSTMENT SCREW	1
23	00708	HEIGHT ADJUSTMENT SHAFT	1
24	A6101	DIA. 1/4 x 1/2 SPRING PIN	1
25	00710	SEAL HEIGHT ADJUSTMENT SHAFT	1
26	A1098	1/2-13 x 6 HEX HEAD BOLT	2
27	A2194	1/2 SAE FLAT WASHER	8
28	A2054	1/2-13 NYLOCK NUT	2
29	00108	RAIL WHEEL	2
30	00109	RAIL WHEEL BEARING	4

SOME ITEM NUMBERS OMITTED FROM CABLE DRIVE GRINDER

**02715
DRIVE PLATE ASSEMBLY**

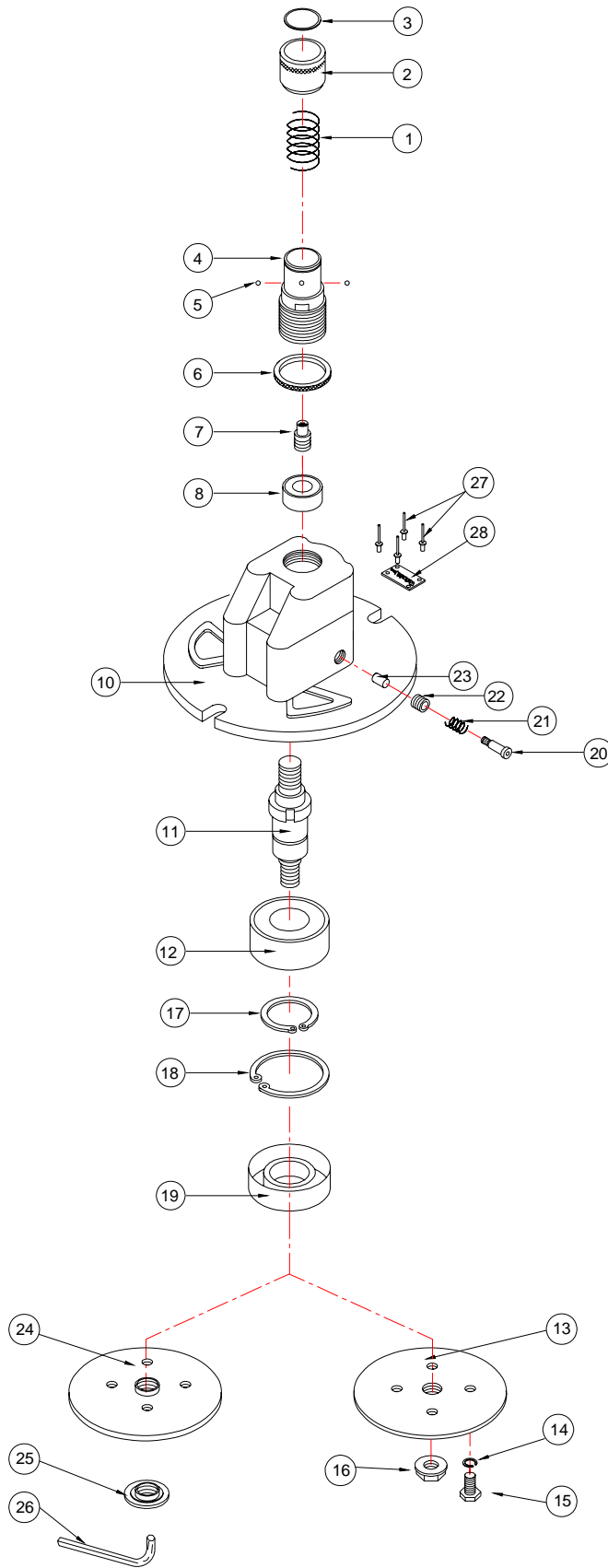

TYPE 6 STONE ADAPTER

PLATE MOUNTED STONE ADAPTER

MATWELD, INC.

PHONE:(270) 444-0085

FAX:(270) 443-6180

Matweld reserves the right to change parts, features, or specifications without notice.

**02715
DRIVE PLATE ASSEMBLY**

ITEM NO.	PART NO.	DESCRIPTION	QTY.
1	02714	SPRING	1
2	02712	COUPLER RING	1
3	02713	RETAINING RING	1
4	02710	COUPLER BODY	1
5	02711	7/32 BALL BEARING	4
6	02709	ADJUSTMENT NUT	1
7	02708	SPLINE DRIVE	1
8	02719A	SECONDARY DRIVE BEARING	1
10	02702A	DRIVE PLATE DUAL BEARING	1
11	02701A	DRIVE SHAFT DUAL BEARING	1
12	00406	DRIVE SHAFT BEARING	1
13	00604	STONE PLATE ADAPTER	1
14	A3813	1/2 LOCK WASHER	4
15	A1081	1/2-20 x 3/4 HEX HEAD BOLT	4
16	A2063	5/8-11 FLANGE NUT	1
17	00405	EXTERNAL RETAINING RING	1
18	00403	INTERNAL RETAINING RING	1
19	00404	SEAL	1
20	A6910	DIA. 1/4 x 1 SHOULDER BOLT	1
21	00413	SPRING	1
22	00415	PLUG	1
23	00412	LOCKING PIN	1
(24)	00733	STONE FLANGE TYPE 6	1
(25)	00734	FLANGE RETAINER TYPE 6	1
(26)	02718	3/8 HEX WRENCH	1
27	SSB4-6S	1/8 x 3/8 SS RIVETS	4
28	SERIAL TAG	SERIAL NUMBER TAG	1

** SOLD IN KIT FORM ONLY
() SOLD IN 0733-KIT

ACCESSORIES/ASSEMBLIES

00720 HEAD ASSEMBLY WITH MOTOR
 00725 HEAD ASSEMBLY WITHOUT MOTOR
 0733-KIT TYPE 6 STONE ADAPTER
 00798 TYPE 6 STONE 8" x 2" x 4"
 00799 PLATE MOUNTED STONE 8" x 2" x 4"

DECAL LEGEND:



THIS STICKER NOT
REQUIRED ON 02700

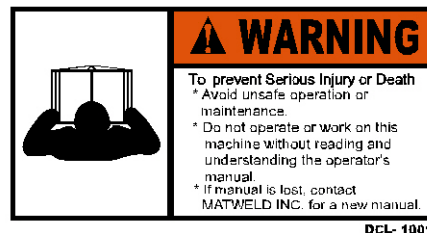

LIMITED WARRANTY

MATWELD, INC., PADUCAH, KY., WARRANTS TO THE ORIGINAL PURCHASER OF THIS PRODUCT THAT THE PRODUCT WILL BE FREE FROM DEFECTS IN MATERIAL AND WORKMANSHIP FOR THE PERIOD OF ONE (1) YEAR AFTER THE DELIVERY OF SUCH PRODUCT TO THE CUSTOMER. OTHER EQUIPMENT AND PARTS USED, BUT NOT MANUFACTURED BY MATWELD INC. ARE COVERED DIRECTLY BY THE WARRANTY OF THE MANUFACTURER OF THOSE PRODUCTS. PROOF OF PURCHASE MUST BE DOCUMENTED INCLUDING REFERENCE TO A SERIAL NUMBER LOCATED ON EACH TOOL. THE PURCHASER'S ONLY REMEDIES UNDER THIS LIMITED WARRANTY SHALL BE LIMITED AT MATWELD'S SOLE OPTION TO THE FOLLOWING: REPAIR, REPLACEMENT OR REFUND OF THE PURCHASE PRICE OF THE DEFECTIVE PRODUCTS. EACH OF THESE REMEDIES REQUIRES TIMELY NOTIFICATION OF THE DEFECT IN THE PRODUCT AND SUBSTANTIATION THAT THE PRODUCT HAS BEEN PROPERLY STORED, MAINTAINED AND USED. MATWELD'S OBLIGATIONS HEREUNDER EXTEND ONLY TO THE PURCHASER OF THE PRODUCT AND NOT TO ANY THIRD PARTY.

AS A CONDITION PRECEDENT TO MATWELD'S OBLIGATION HEREUNDER, THE DEFECTIVE PRODUCT MUST NOT HAVE BEEN ALTERED OR MODIFIED WITHOUT THE EXPRESS WRITTEN APPROVAL OF MATWELD, INC. THE PRODUCT MUST NOT HAVE BEEN SUBJECTED TO DELIBERATE DAMAGE, SHIPPING DAMAGE, NEGLIGENCE, TAMPERING BY UNAUTHORIZED PERSONNEL OR DAMAGE BY IMPROPER USE, STORAGE OR MAINTENANCE. SERIAL NUMBERS MUST NOT HAVE BEEN ALTERED, DEFACED OR REMOVED. SUCH ACTION VOIDS LIMITED WARRANTY.

EXCLUSIONS TO LIMITED WARRANTY

THIS LIMITED WARRANTY IS EXCLUSIVE AND IS IN LIEU OF ANY OTHER WARRANTY, WRITTEN OR ORAL, EXPRESSED OR IMPLIED, INCLUDING, WITHOUT LIMITATION, ANY IMPLIED WARRANTY OR MERCHANTABILITY OR FITNESS FOR A PARTICULAR PURPOSE.

LIMITED WARRANTY DOES NOT COVER NORMAL WEAR AND TEAR ITEMS SUCH AS FILTERS, HOSES, COUPLERS, BITS, SOCKETS, AUGERS, AND BATTERIES.

LIMITATION OF LIABILITY

EXCEPT AS PROVIDED ABOVE, MATWELD SHALL IN NO EVENT BE LIABLE OR RESPONSIBLE FOR ANY INJURY, LOSS OR DAMAGE, DIRECT, INCIDENTAL OR CONSEQUENTIAL, ARISING OUT OF THE USE OR MISUSE OR INABILITY TO USE THE PRODUCT, HOWEVER CAUSED AND ON ANY THEORY OF LIABILITY INCLUDING, WITHOUT LIMITATIONS, BREACH OF CONTRACT, TORT, (INCLUDING NEGLIGENCE OR STREET LIABILITY) AND NOT WITHSTANDING ANY FAILURE OF ANY REMEDY HEREIN OF ITS ESSENTIAL PURPOSE, EVEN IF MATWELD WAS AWARE OF THIS POSSIBILITY OF SUCH DAMAGE. MATWELD'S LIMITED WARRANTY AS SET FORTH ABOVE SHALL NOT BE ENLARGED, DIMINISHED OR AFFECTED BY, AND NO OBLIGATION OR LIABILITY SHALL ARISE OR GO OUT OF THE RENDERING OF TECHNICAL ADVICE OR SERVICE BY MATWELD OR ITS AGENTS. THE FOREGOING MAY NOT BE CHANGED EXCEPT BY WRITTEN AGREEMENT SIGNED BY AN AUTHORIZED OFFICER OF MATWELD, THE REMEDIES SET FORTH HEREIN ARE EXCLUSIVE.

MATWELD, INC.

PHONE:(270) 444-0085

FAX:(270) 443-6180

Matweld reserves the right to change parts, features, or specifications without notice.

CUSTOMER INFORMATION:

Name _____

Company _____

Serial # of your Matweld tool _____

(Upon receiving your Matweld tool, make sure to list serial number above so that a good record is kept for order information.)

MATWELD HYDRAULIC TOOL LIST

All Matweld Hydraulic Tools operate at 5 or 10 GPM @ 2000 PSI

POWER UNITS:

00100K – GASOLINE POWERED (1) 10 GPM OR (2) 5 GPM CIRCUITS

02900A – DIESEL (1) 10 GPM OR (2) 5 GPM CIRCUITS

(OPTIONAL CATALYTIC EXHAUST AND/OR MSHA CERTIFIED)

05500 – TWIN POWER DUAL CIRCUIT (1) 10 GPM OR (2) 5 GPM CIRCUITS & 5000 WATT GENERATOR

02050K – GASOLINE POWERED (1) 5 GPM

03700A – ELECTRIC POWER (1) 10 GPM OR (2) 5 GPM CIRCUITS

GRINDERS:

09200A – PRECISION FROG GRINDER

06000 – PROFILE GRINDER

06900 & 06900A – MULTI-PURPOSE GRINDER (TRIGGER VERSION AVAILABLE)

05900 – FROG/PROFILE GRINDER (TRIGGER VERSION AVAILABLE)

00700 – RAIL SURFACING GUIDE

04600 – STRAIGHT STONE CW ROTATION (TRIGGER VERSION AVAILABLE)

04700 – STRAIGHT STONE CCW ROTATION (TRIGGER VERSION AVAILABLE)

07500 – CHAMFER TOOL

04800 – CUP STONE GRINDER (TRIGGER VERSION AVAILABLE)

00600C – CUP STONE GRINDER

05400 – ANGLE GRINDER

05600 – BULL NOSE GRINDER

02400 – 10" OR 14" FROG AND SWITCH GRINDER

TRACK TOOLS:

03900A – REVERSING RAIL SAW

05100A & 05100B – POWER WELD SHEAR

03500 – SELF FEED RAIL DRILL

01600A – 5 GPM 1" IMPACT WRENCH

04500D – 1/2" HYDRAULIC DRILL IMPACT WRENCH

08200 – TAMPER

02800 – 60 TON BRIDGE SPREADER

01200 – SPRING ANCHOR APPLICATOR

01100A – SPIKE PULLER (SINGLE, 2 STAGE & TRIGGER VERSIONS AVAILABLE)

00800A – 16" RAIL SAW

05000 – HAND PUMP WELD SHEAR

01500 – RAIL DRILL

02500 – 10 GPM 1" IMPACT WRENCH

03100C – RAIL PULLER

08300 – SPIKE DRIVER

07650 – HYDRAULIC CLIP TOOL

OTHER PRODUCTS:

HYDRAULIC MANIFOLDS

HYDRAULIC TEST GAUGES

HOSE REELS

HYDRAULIC HOSES

ACCESSORIES

MATWELD, INC.

PHONE:(270) 444-0085

FAX:(270) 443-6180

Matweld reserves the right to change parts, features, or specifications without notice.