



OM-278792J

2020-01

**Processes**



MIG (GMAW) Welding

Flux Cored (FCAW) Welding

**Description**



Wire Feeder

# ArcReach<sup>®</sup> SuitCase<sup>®</sup> 12 CE And Non-CE Models

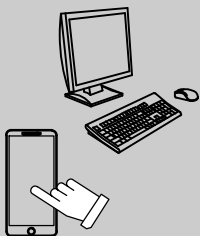
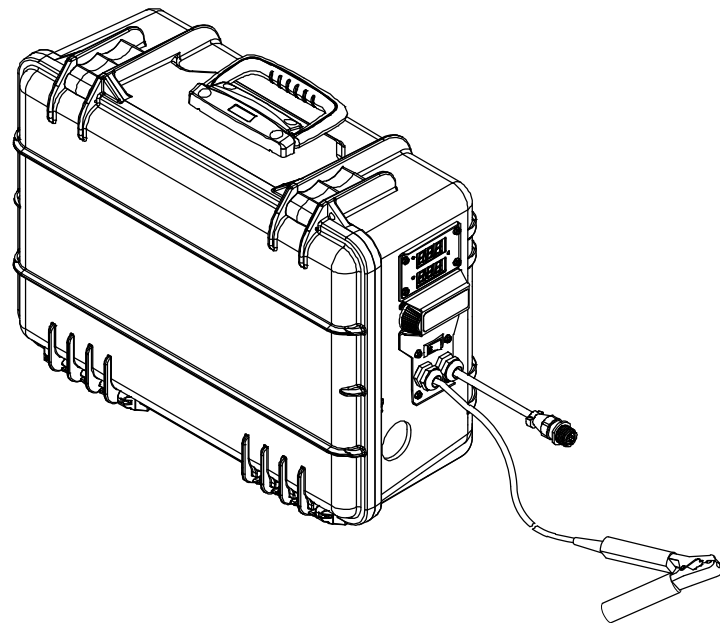

For product information,  
Owner's Manual translations,  
and more, visit

[www.MillerWelds.com](http://www.MillerWelds.com)

## OWNER'S MANUAL

File: MIG (GMAW)



# From Miller to You

---

*Thank you and congratulations* on choosing Miller. Now you can get the job done and get it done right. We know you don't have time to do it any other way.

That's why when Niels Miller first started building arc welders in 1929, he made sure his products offered long-lasting value and superior quality. Like you, his customers couldn't afford anything less. Miller products had to be more than the best they could be. They had to be the best you could buy.

Today, the people that build and sell Miller products continue the tradition. They're just as committed to providing equipment and service that meets the high standards of quality and value established in 1929.

This Owner's Manual is designed to help you get the most out of your Miller products. Please take time to read the Safety Precautions. They will help you protect yourself against potential hazards on the worksite.



ISO 9001  
Quality

Miller is the first welding equipment manufacturer in the U.S.A. to be registered to the ISO 9001 Quality System Standard.

We've made installation and operation quick and easy. With Miller, you can count on years of reliable service with proper maintenance. And if for some reason the unit needs repair, there's a Troubleshooting section that will help you figure out what the problem is, and our extensive service network is there to help fix the problem. Warranty and maintenance information for your particular model are also provided.



Miller Electric manufactures a full line of welders and welding-related equipment. For information on other quality Miller products, contact your local Miller distributor to receive the latest full line catalog or individual specification sheets. **To locate your nearest distributor or service agency call 1-800-4-A-Miller, or visit us at [www.MillerWelds.com](http://www.MillerWelds.com) on the web.**



Working as hard as you do – every power source from Miller is backed by the most hassle-free warranty in the business.



# TABLE OF CONTENTS

<b>SECTION 1 – SAFETY PRECAUTIONS - READ BEFORE USING</b> .....	<b>1</b>
1-1. Symbol Usage .....	1
1-2. Arc Welding Hazards .....	1
1-3. Additional Symbols For Installation, Operation, And Maintenance .....	3
1-4. California Proposition 65 Warnings .....	4
1-5. Principal Safety Standards .....	4
1-6. EMF Information .....	4
<b>SECTION 2 – CONSIGNES DE SÉCURITÉ – LIRE AVANT UTILISATION</b> .....	<b>5</b>
2-1. Symboles utilisés .....	5
2-2. Dangers relatifs au soudage à l'arc .....	5
2-3. Dangers supplémentaires en relation avec l'installation, le fonctionnement et la maintenance .....	7
2-4. Proposition californienne 65 Avertissements .....	8
2-5. Principales normes de sécurité .....	8
2-6. Informations relatives aux CEM .....	8
<b>SECTION 3 – DEFINITIONS</b> .....	<b>9</b>
3-1. Additional Safety Symbols And Definitions .....	9
3-2. Miscellaneous Symbols And Definitions .....	10
<b>SECTION 4 – SPECIFICATIONS</b> .....	<b>11</b>
4-1. Serial Number And Rating Label Location .....	11
4-2. Unit Specifications .....	11
4-3. Environmental Specifications .....	11
4-4. Wire Type, Size, and Feed Speed Capability Table .....	11
4-5. Gun Recommendation Table .....	11
<b>SECTION 5 – INSTALLATION</b> .....	<b>12</b>
5-1. Equipment Connection Diagram .....	12
5-2. ArcReach Applications .....	12
5-3. Associating Wire Feeder To ArcReach Compatible Power Source Or ArcReach Control .....	12
5-4. Equipment Setup .....	13
5-5. Installing Drive Rolls .....	14
5-6. Connecting Welding Gun And Voltage Sensing Clamp .....	15
5-7. Connecting Shielding Gas .....	16
5-8. Connecting Weld Cable .....	16
5-9. Selecting Cable Sizes* .....	17
5-10. Installing And Threading Welding Wire .....	18
5-11. Motor Board (PC1) DIP Switch Settings .....	18
5-12. Meter Board (PC22) DIP Switch Settings .....	20
<b>SECTION 6 – OPERATION</b> .....	<b>22</b>
6-1. Controls .....	22
6-2. Cable Length Compensation (CLC) .....	23
6-3. Wire Speed Dual Schedule .....	24
6-4. Wire Speed Control Settings .....	25
<b>SECTION 7 – MAINTENANCE &amp; TROUBLESHOOTING</b> .....	<b>26</b>
7-1. Routine Maintenance .....	26
7-2. Overload Protection And Thermostat Protection .....	26
7-3. Cleaning Debris From Shielding Gas Filter Fitting .....	27
7-4. Troubleshooting .....	28
7-5. Diagnostics .....	30
<b>SECTION 8 – ELECTRICAL DIAGRAM</b> .....	<b>31</b>
<b>SECTION 9 – PARTS LIST</b> .....	<b>32</b>
<b>SECTION 10 – OPEN SOURCE LICENSE NOTICES</b> .....	<b>39</b>
<b>WARRANTY</b>	



# DECLARATION OF CONFORMITY

for European Community (CE marked) products.

**MILLER Electric Mfg. Co., 1635 Spencer Street, Appleton, WI 54914 U.S.A. declares that the product(s) identified in this declaration conform to the essential requirements and provisions of the stated Council Directive(s) and Standard(s).**

Product/Apparatus Identification:

Product	Stock Number
ArcReach SuitCase 12	301456

Council Directives:

- 2014/35/EU Low voltage
- 2014/30/EU Electromagnetic compatibility
- 2011/65/EU Restriction of the use of certain hazardous substances in electrical and electronic equipment

Standards:

- IEC 60974-5:2013 Arc welding equipment – Part 5: Wire feeders
- IEC 60974-10:2014 Arc welding equipment – Part 10: Electromagnetic compatibility requirements

Signatory:

August 25, 2017

---

**David A. Werba**

MANAGER, PRODUCT DESIGN COMPLIANCE

---

Date of Declaration

# SECTION 1 – SAFETY PRECAUTIONS - READ BEFORE USING

som 2018-01

**⚠** Protect yourself and others from injury — read, follow, and save these important safety precautions and operating instructions.

## 1-1. Symbol Usage



**DANGER!** – Indicates a hazardous situation which, if not avoided, will result in death or serious injury. The possible hazards are shown in the adjoining symbols or explained in the text.



Indicates a hazardous situation which, if not avoided, could result in death or serious injury. The possible hazards are shown in the adjoining symbols or explained in the text.

**NOTICE** – Indicates statements not related to personal injury.

 Indicates special instructions.



This group of symbols means Warning! Watch Out! ELECTRIC SHOCK, MOVING PARTS, and HOT PARTS hazards. Consult symbols and related instructions below for necessary actions to avoid the hazards.

## 1-2. Arc Welding Hazards



The symbols shown below are used throughout this manual to call attention to and identify possible hazards. When you see the symbol, watch out, and follow the related instructions to avoid the hazard. The safety information given below is only a summary of the more complete safety information found in the Safety Standards listed in Section 1-5. Read and follow all Safety Standards.



Only qualified persons should install, operate, maintain, and repair this equipment. A qualified person is defined as one who, by possession of a recognized degree, certificate, or professional standing, or who by extensive knowledge, training and experience, has successfully demonstrated ability to solve or resolve problems relating to the subject matter, the work, or the project and has received safety training to recognize and avoid the hazards involved.



During operation, keep everybody, especially children, away.



### ELECTRIC SHOCK can kill.

Touching live electrical parts can cause fatal shocks or severe burns. The electrode and work circuit is electrically live whenever the output is on. The input power circuit and machine internal circuits are also live when power is on. In semiautomatic or automatic wire welding, the wire, wire reel, drive roll housing, and all metal parts touching the welding wire are electrically live. Incorrectly installed or improperly grounded equipment is a hazard.

- Do not touch live electrical parts.

- Wear dry, hole-free insulating gloves and body protection.
- Insulate yourself from work and ground using dry insulating mats or covers big enough to prevent any physical contact with the work or ground.
- Do not use AC weld output in damp, wet, or confined spaces, or if there is a danger of falling.
- Use AC output ONLY if required for the welding process.
- If AC output is required, use remote output control if present on unit.
- Additional safety precautions are required when any of the following electrically hazardous conditions are present: in damp locations or while wearing wet clothing; on metal structures such as floors, gratings, or scaffolds; when in cramped positions such as sitting, kneeling, or lying; or when there is a high risk of unavoidable or accidental contact with the workpiece or ground. For these conditions, use the following equipment in order presented: 1) a semiautomatic DC constant voltage (wire) welder, 2) a DC manual (stick) welder, or 3) an AC welder with reduced open-circuit voltage. In most situations, use of a DC, constant voltage wire welder is recommended. And, do not work alone!
- Disconnect input power or stop engine before installing or servicing this equipment. Lockout/tagout input power according to OSHA 29 CFR 1910.147 (see Safety Standards).

- Properly install, ground, and operate this equipment according to its Owner's Manual and national, state, and local codes.
- Always verify the supply ground – check and be sure that input power cord ground wire is properly connected to ground terminal in disconnect box or that cord plug is connected to a properly grounded receptacle outlet.
- When making input connections, attach proper grounding conductor first – double-check connections.
- Keep cords dry, free of oil and grease, and protected from hot metal and sparks.
- Frequently inspect input power cord and ground conductor for damage or bare wiring – replace immediately if damaged – bare wiring can kill.
- Turn off all equipment when not in use.
- Do not use worn, damaged, undersized, or repaired cables.
- Do not drape cables over your body.
- If earth grounding of the workpiece is required, ground it directly with a separate cable.
- Do not touch electrode if you are in contact with the work, ground, or another electrode from a different machine.
- Do not touch electrode holders connected to two welding machines at the same time since double open-circuit voltage will be present.
- Use only well-maintained equipment. Repair or replace damaged parts at once. Maintain unit according to manual.
- Wear a safety harness if working above floor level.
- Keep all panels and covers securely in place.
- Clamp work cable with good metal-to-metal contact to workpiece or worktable as near the weld as practical.
- Insulate work clamp when not connected to workpiece to prevent contact with any metal object.
- Do not connect more than one electrode or work cable to any single weld output terminal. Disconnect cable for process not in use.
- Use GFCI protection when operating auxiliary equipment in damp or wet locations.

### SIGNIFICANT DC VOLTAGE exists in inverter welding power sources AFTER removal of input power.

- Turn off unit, disconnect input power, and discharge input capacitors according to instructions in Manual before touching any parts.



### HOT PARTS can burn.

- Do not touch hot parts bare handed.
- Allow cooling period before working on equipment.
- To handle hot parts, use proper tools and/or wear heavy, insulated welding gloves and clothing to prevent burns.



### FUMES AND GASES can be hazardous.

Welding produces fumes and gases. Breathing these fumes and gases can be hazardous to your health.

- Keep your head out of the fumes. Do not breathe the fumes.
- Ventilate the work area and/or use local forced ventilation at the arc to remove welding fumes and gases. The recommended way to determine adequate ventilation is to sample for the composition and quantity of fumes and gases to which personnel are exposed.
- If ventilation is poor, wear an approved air-supplied respirator.
- Read and understand the Safety Data Sheets (SDSs) and the manufacturer's instructions for adhesives, coatings, cleaners, consumables, coolants, degreasers, fluxes, and metals.
- Work in a confined space only if it is well ventilated, or while wearing an air-supplied respirator. Always have a trained watchperson nearby. Welding fumes and gases can displace air and lower the oxygen level causing injury or death. Be sure the breathing air is safe.
- Do not weld in locations near degreasing, cleaning, or spraying operations. The heat and rays of the arc can react with vapors to form highly toxic and irritating gases.
- Do not weld on coated metals, such as galvanized, lead, or cadmium plated steel, unless the coating is removed from the weld area, the area is well ventilated, and while wearing an air-supplied respirator. The coatings and any metals containing these elements can give off toxic fumes if welded.



### ARC RAYS can burn eyes and skin.

Arc rays from the welding process produce intense visible and invisible (ultraviolet and infrared) rays that can burn eyes and skin. Sparks fly off from the weld.

- Wear an approved welding helmet fitted with a proper shade of filter lenses to protect your face and eyes from arc rays and sparks when welding or watching (see ANSI Z49.1 and Z87.1 listed in Safety Standards).
- Wear approved safety glasses with side shields under your helmet.
- Use protective screens or barriers to protect others from flash, glare and sparks; warn others not to watch the arc.
- Wear body protection made from durable, flame-resistant material (leather, heavy cotton, wool). Body protection includes oil-free clothing such as leather gloves, heavy shirt, cuffless trousers, high shoes, and a cap.



### WELDING can cause fire or explosion.

Welding on closed containers, such as tanks, drums, or pipes, can cause them to blow up. Sparks can fly off from the welding arc. The flying sparks, hot workpiece, and hot equipment can cause fires and burns. Accidental contact of electrode to metal objects can cause sparks, explosion, overheating, or fire. Check and be sure the area is safe before doing any welding.

- Remove all flammables within 35 ft (10.7 m) of the welding arc. If this is not possible, tightly cover them with approved covers.
- Do not weld where flying sparks can strike flammable material.
- Protect yourself and others from flying sparks and hot metal.
- Be alert that welding sparks and hot materials from welding can easily go through small cracks and openings to adjacent areas.
- Watch for fire, and keep a fire extinguisher nearby.
- Be aware that welding on a ceiling, floor, bulkhead, or partition can cause fire on the hidden side.

- Do not cut or weld on tire rims or wheels. Tires can explode if heated. Repaired rims and wheels can fail. See OSHA 29 CFR 1910.177 listed in Safety Standards.
- Do not weld on containers that have held combustibles, or on closed containers such as tanks, drums, or pipes unless they are properly prepared according to AWS F4.1 and AWS A6.0 (see Safety Standards).
- Do not weld where the atmosphere can contain flammable dust, gas, or liquid vapors (such as gasoline).
- Connect work cable to the work as close to the welding area as practical to prevent welding current from traveling long, possibly unknown paths and causing electric shock, sparks, and fire hazards.
- Do not use welder to thaw frozen pipes.
- Remove stick electrode from holder or cut off welding wire at contact tip when not in use.
- Wear body protection made from durable, flame-resistant material (leather, heavy cotton, wool). Body protection includes oil-free clothing such as leather gloves, heavy shirt, cuffless trousers, high shoes, and a cap.
- Remove any combustibles, such as a butane lighter or matches, from your person before doing any welding.
- After completion of work, inspect area to ensure it is free of sparks, glowing embers, and flames.
- Use only correct fuses or circuit breakers. Do not oversize or bypass them.
- Follow requirements in OSHA 1910.252 (a) (2) (iv) and NFPA 51B for hot work and have a fire watcher and extinguisher nearby.
- Read and understand the Safety Data Sheets (SDSs) and the manufacturer's instructions for adhesives, coatings, cleaners, consumables, coolants, degreasers, fluxes, and metals.

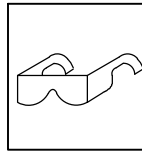

### FLYING METAL or DIRT can injure eyes.

- Welding, chipping, wire brushing, and grinding cause sparks and flying metal. As welds cool, they can throw off slag.
- Wear approved safety glasses with side shields even under your welding helmet.



### BUILDUP OF GAS can injure or kill.

- Shut off compressed gas supply when not in use.
- Always ventilate confined spaces or use approved air-supplied respirator.

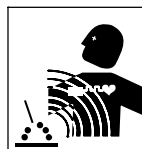

### ELECTRIC AND MAGNETIC FIELDS (EMF) can affect Implanted Medical Devices.

- Wearers of Pacemakers and other Implanted Medical Devices should keep away.
- Implanted Medical Device wearers should consult their doctor and the device manufacturer before going near arc welding, spot welding, gouging, plasma arc cutting, or induction heating operations.

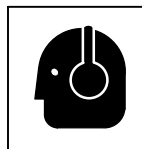

### NOISE can damage hearing.

Noise from some processes or equipment can damage hearing.

- Wear approved ear protection if noise level is high.



### CYLINDERS can explode if damaged.

Compressed gas cylinders contain gas under high pressure. If damaged, a cylinder can explode. Since gas cylinders are normally part of the welding process, be sure to treat them carefully.

- Protect compressed gas cylinders from excessive heat, mechanical shocks, physical damage, slag, open flames, sparks, and arcs.
- Install cylinders in an upright position by securing to a stationary support or cylinder rack to prevent falling or tipping.
- Keep cylinders away from any welding or other electrical circuits.
- Never drape a welding torch over a gas cylinder.
- Never allow a welding electrode to touch any cylinder.

- Never weld on a pressurized cylinder – explosion will result.
- Use only correct compressed gas cylinders, regulators, hoses, and fittings designed for the specific application; maintain them and associated parts in good condition.
- Turn face away from valve outlet when opening cylinder valve. Do not stand in front of or behind the regulator when opening the valve.
- Keep protective cap in place over valve except when cylinder is in use or connected for use.
- Use the proper equipment, correct procedures, and sufficient number of persons to lift, move, and transport cylinders.
- Read and follow instructions on compressed gas cylinders, associated equipment, and Compressed Gas Association (CGA) publication P-1 listed in Safety Standards.

## 1-3. Additional Symbols For Installation, Operation, And Maintenance



### FIRE OR EXPLOSION hazard.

- Do not install or place unit on, over, or near combustible surfaces.
- Do not install unit near flammables.
- Do not overload building wiring – be sure power supply system is properly sized, rated, and protected to handle this unit.



### FALLING EQUIPMENT can injure.

- Use lifting eye to lift unit only, NOT running gear, gas cylinders, or any other accessories.
- Use correct procedures and equipment of adequate capacity to lift and support unit.
- If using lift forks to move unit, be sure forks are long enough to extend beyond opposite side of unit.
- Keep equipment (cables and cords) away from moving vehicles when working from an aerial location.
- Follow the guidelines in the Applications Manual for the Revised NIOSH Lifting Equation (Publication No. 94-110) when manually lifting heavy parts or equipment.

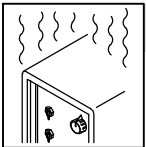

### OVERUSE can cause OVERHEATING

- Allow cooling period; follow rated duty cycle.
- Reduce current or reduce duty cycle before starting to weld again.
- Do not block or filter airflow to unit.

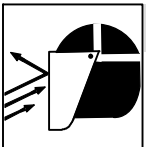

### FLYING SPARKS can injure.

- Wear a face shield to protect eyes and face.
- Shape tungsten electrode only on grinder with proper guards in a safe location wearing proper face, hand, and body protection.
- Sparks can cause fires — keep flammables away.

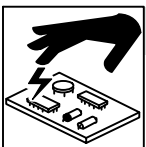

### STATIC (ESD) can damage PC boards.

- Put on grounded wrist strap BEFORE handling boards or parts.
- Use proper static-proof bags and boxes to store, move, or ship PC boards.

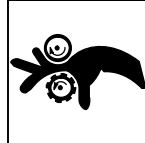

### MOVING PARTS can injure.

- Keep away from moving parts.
- Keep away from pinch points such as drive rolls.



### WELDING WIRE can injure.

- Do not press gun trigger until instructed to do so.
- Do not point gun toward any part of the body, other people, or any metal when threading welding wire.

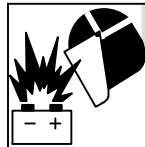

### BATTERY EXPLOSION can injure.

- Do not use welder to charge batteries or jump start vehicles unless it has a battery charging feature designed for this purpose.



### MOVING PARTS can injure.

- Keep away from moving parts such as fans.
- Keep all doors, panels, covers, and guards closed and securely in place.
- Have only qualified persons remove doors, panels, covers, or guards for maintenance and troubleshooting as necessary.
- Reinstall doors, panels, covers, or guards when maintenance is finished and before reconnecting input power.

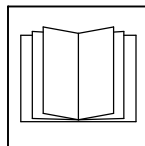

### READ INSTRUCTIONS.

- Read and follow all labels and the Owner's Manual carefully before installing, operating, or servicing unit. Read the safety information at the beginning of the manual and in each section.
- Use only genuine replacement parts from the manufacturer.
- Perform installation, maintenance, and service according to the Owner's Manuals, industry standards, and national, state, and local codes.

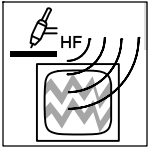

### H.F. RADIATION can cause interference.

- High-frequency (H.F.) can interfere with radio navigation, safety services, computers, and communications equipment.
- Have only qualified persons familiar with electronic equipment perform this installation.
- The user is responsible for having a qualified electrician promptly correct any interference problem resulting from the installation.
- If notified by the FCC about interference, stop using the equipment at once.
- Have the installation regularly checked and maintained.
- Keep high-frequency source doors and panels tightly shut, keep spark gaps at correct setting, and use grounding and shielding to minimize the possibility of interference.

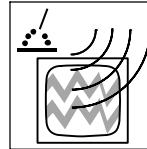

### ARC WELDING can cause interference.

- Electromagnetic energy can interfere with sensitive electronic equipment such as computers and computer-driven equipment such as robots.
- Be sure all equipment in the welding area is electromagnetically compatible.
- To reduce possible interference, keep weld cables as short as possible, close together, and down low, such as on the floor.
- Locate welding operation 100 meters from any sensitive electronic equipment.
- Be sure this welding machine is installed and grounded according to this manual.
- If interference still occurs, the user must take extra measures such as moving the welding machine, using shielded cables, using line filters, or shielding the work area.

## 1-4. California Proposition 65 Warnings

**⚠ WARNING:** This product can expose you to chemicals including lead, which are known to the state of California to cause cancer and birth defects or other reproductive harm.

For more information, go to [www.P65Warnings.ca.gov](http://www.P65Warnings.ca.gov).

## 1-5. Principal Safety Standards

*Safety in Welding, Cutting, and Allied Processes*, ANSI Standard Z49.1, is available as a free download from the American Welding Society at <http://www.aws.org> or purchased from Global Engineering Documents (phone: 1-877-413-5184, website: [www.global.ihs.com](http://www.global.ihs.com)).

*Safe Practices for the Preparation of Containers and Piping for Welding and Cutting*, American Welding Society Standard AWS F4.1, from Global Engineering Documents (phone: 1-877-413-5184, website: [www.global.ihs.com](http://www.global.ihs.com)).

*Safe Practices for Welding and Cutting Containers that have Held Combustibles*, American Welding Society Standard AWS A6.0, from Global Engineering Documents (phone: 1-877-413-5184, website: [www.global.ihs.com](http://www.global.ihs.com)).

*National Electrical Code*, NFPA Standard 70, from National Fire Protection Association, Quincy, MA 02169 (phone: 1-800-344-3555, website: [www.nfpa.org](http://www.nfpa.org) and [www.sparky.org](http://www.sparky.org)).

*Safe Handling of Compressed Gases in Cylinders*, CGA Pamphlet P-1, from Compressed Gas Association, 14501 George Carter Way, Suite 103, Chantilly, VA 20151 (phone: 703-788-2700, website: [www.cganet.com](http://www.cganet.com)).

*Safety in Welding, Cutting, and Allied Processes*, CSA Standard W117.2, from Canadian Standards Association, Standards Sales, 5060 Spectrum Way, Suite 100, Mississauga, Ontario, Canada L4W 5N5 (phone: 800-463-6727, website: [www.csagroup.org](http://www.csagroup.org)).

*Safe Practice For Occupational And Educational Eye And Face Protection*, ANSI Standard Z87.1, from American National Standards Institute, 25 West 43rd Street, New York, NY 10036 (phone: 212-642-4900, website: [www.ansi.org](http://www.ansi.org)).

*Standard for Fire Prevention During Welding, Cutting, and Other Hot Work*, NFPA Standard 51B, from National Fire Protection Association, Quincy, MA 02169 (phone: 1-800-344-3555, website: [www.nfpa.org](http://www.nfpa.org)).

OSHA, Occupational Safety and Health Standards for General Industry, Title 29, Code of Federal Regulations (CFR), Part 1910.177 Subpart N, Part 1910 Subpart Q, and Part 1926, Subpart J, from U.S. Government Printing Office, Superintendent of Documents, P.O. Box 371954, Pittsburgh, PA 15250-7954 (phone: 1-866-512-1800) (there are 10 OSHA Regional Offices—phone for Region 5, Chicago, is 312-353-2220, website: [www.osha.gov](http://www.osha.gov)).

*Applications Manual for the Revised NIOSH Lifting Equation*, The National Institute for Occupational Safety and Health (NIOSH), 1600 Clifton Rd, Atlanta, GA 30329-4027 (phone: 1-800-232-4636, website: [www.cdc.gov/NIOSH](http://www.cdc.gov/NIOSH)).

## 1-6. EMF Information

Electric current flowing through any conductor causes localized electric and magnetic fields (EMF). The current from arc welding (and allied processes including spot welding, gouging, plasma arc cutting, and induction heating operations) creates an EMF field around the welding circuit. EMF fields can interfere with some medical implants, e.g. pacemakers. Protective measures for persons wearing medical implants have to be taken. For example, restrict access for passers-by or conduct individual risk assessment for welders. All welders should use the following procedures in order to minimize exposure to EMF fields from the welding circuit:

1. Keep cables close together by twisting or taping them, or using a cable cover.
2. Do not place your body between welding cables. Arrange cables to one side and away from the operator.
3. Do not coil or drape cables around your body.

4. Keep head and trunk as far away from the equipment in the welding circuit as possible.
5. Connect work clamp to workpiece as close to the weld as possible.
6. Do not work next to, sit or lean on the welding power source.
7. Do not weld whilst carrying the welding power source or wire feeder.

### About Implanted Medical Devices:

Implanted Medical Device wearers should consult their doctor and the device manufacturer before performing or going near arc welding, spot welding, gouging, plasma arc cutting, or induction heating operations. If cleared by your doctor, then following the above procedures is recommended.



# SECTION 2 – CONSIGNES DE SÉCURITÉ – LIRE AVANT UTILISATION

som\_2018-01\_fre

**⚠** Pour écarter les risques de blessure pour vous-même et pour autrui — lire, appliquer et ranger en lieu sûr ces consignes relatives aux précautions de sécurité et au mode opératoire.

## 2-1. Symboles utilisés



**DANGER!** – Indique une situation dangereuse qui si on l'évite pas peut donner la mort ou des blessures graves. Les dangers possibles sont montrés par les symboles joints ou sont expliqués dans le texte.



Indique une situation dangereuse qui si on l'évite pas peut donner la mort ou des blessures graves. Les dangers possibles sont montrés par les symboles joints ou sont expliqués dans le texte.

**AVIS** – Indique des déclarations pas en relation avec des blessures personnelles.

 Indique des instructions spécifiques.



Ce groupe de symboles veut dire Avertissement! Attention! DANGER DE CHOC ÉLECTRIQUE, PIÈCES EN MOUVEMENT, et PIÈCES CHAUDES. Consulter les symboles et les instructions ci-dessous y afférant pour les actions nécessaires afin d'éviter le danger.

## 2-2. Dangers relatifs au soudage à l'arc



Les symboles représentés ci-dessous sont utilisés dans ce manuel pour attirer l'attention et identifier les dangers possibles. En présence de l'un de ces symboles, prendre garde et suivre les instructions afférentes pour éviter tout risque. Les instructions en matière de sécurité indiquées ci-dessous ne constituent qu'un sommaire des instructions de sécurité plus complètes fournies dans les normes de sécurité énumérées dans la Section 2-5. Lire et observer toutes les normes de sécurité.



L'installation, l'utilisation, l'entretien et les réparations ne doivent être confiés qu'à des personnes qualifiées. Une personne qualifiée est définie comme celle qui, par la possession d'un diplôme reconnu, d'un certificat ou d'un statut professionnel, ou qui, par une connaissance, une formation et une expérience approfondies, a démontré avec succès sa capacité à résoudre les problèmes liés à la tâche, le travail ou le projet et a reçu une formation en sécurité afin de reconnaître et d'éviter les risques inhérents.



Pendant le fonctionnement, maintenir à distance toutes les personnes, notamment les enfants de l'appareil.



### UNE DÉCHARGE ÉLECTRIQUE peut entraîner la mort.

Le contact d'organes électriques sous tension peut provoquer des accidents mortels ou des brûlures graves. Le circuit de l'électrode et de la pièce est sous tension lorsque le courant est délivré à la sortie. Le circuit d'alimentation et les circuits internes de la machine sont également sous tension lorsque l'alimentation est sur Marche. Dans le mode de soudage avec du fil, le fil, le dérouleur, le bloc de commande du rouleau et toutes les parties métalliques en contact avec le fil sont sous tension électrique. Un équipement installé ou mis à la terre de manière incorrecte ou impropre constitue un danger.

- Ne pas toucher aux pièces électriques sous tension.
- Porter des gants isolants et des vêtements de protection secs et sans trous.
- S'isoler de la pièce à couper et du sol en utilisant des housses ou des tapis assez grands afin d'éviter tout contact physique avec la pièce à couper ou le sol.
- Ne pas utiliser de sortie de soudage CA dans des zones humides ou confinées ou s'il y a un risque de chute.
- Se servir d'une source électrique à courant électrique UNIQUEMENT si le procédé de soudage le demande.
- Si l'utilisation d'une source électrique à courant électrique s'avère nécessaire, se servir de la fonction de télécommande si l'appareil en est équipé.
- D'autres consignes de sécurité sont nécessaires dans les conditions suivantes : risques électriques dans un environnement humide ou si l'on porte des vêtements mouillés ; sur des structures métalliques telles que sols, grilles ou échafaudages ; en position coincée comme assise, à genoux ou couchée ; ou s'il y a un risque élevé de contact inévitable ou accidentel avec la pièce à souder ou le sol. Dans ces conditions, utiliser les équipements suivants, dans l'ordre indiqué : 1) un poste à souder DC à tension constante (à fil), 2) un poste à souder DC manuel (électrode) ou 3) un poste à souder AC à tension à vide réduite. Dans la plupart des situations,

l'utilisation d'un poste à souder DC à fil à tension constante est recommandée. En outre, ne pas travailler seul !

- Couper l'alimentation ou arrêter le moteur avant de procéder à l'installation, à la réparation ou à l'entretien de l'appareil. Déverrouiller l'alimentation selon la norme OSHA 29 CFR 1910.147 (voir normes de sécurité).
- Installez, mettez à la terre et utilisez correctement cet équipement conformément à son Manuel d'Utilisation et aux réglementations nationales, gouvernementales et locales.
- Toujours vérifier la terre du cordon d'alimentation. Vérifier et s'assurer que le fil de terre du cordon d'alimentation est bien raccordé à la borne de terre du sectionneur ou que la fiche du cordon est raccordée à une prise correctement mise à la terre.
- En effectuant les raccordements d'entrée, fixer d'abord le conducteur de mise à la terre approprié et contre-vérifier les connexions.
- Les câbles doivent être exempts d'humidité, d'huile et de graisse; protégez-les contre les étincelles et les pièces métalliques chaudes.
- Vérifier fréquemment le cordon d'alimentation et le conducteur de mise à la terre afin de s'assurer qu'il n'est pas altéré ou dénudé –, le remplacer immédiatement s'il l'est –. Un fil dénudé peut entraîner la mort.
- L'équipement doit être hors tension lorsqu'il n'est pas utilisé.
- Ne pas utiliser des câbles usés, endommagés, de grosseur insuffisante ou mal épissés.
- Ne pas enrouler les câbles autour du corps.
- Si la pièce soudée doit être mise à la terre, le faire directement avec un câble distinct.
- Ne pas toucher l'électrode quand on est en contact avec la pièce, la terre ou une électrode provenant d'une autre machine.
- Ne pas toucher des porte électrodes connectés à deux machines en même temps à cause de la présence d'une tension à vide doublée.
- N'utiliser qu'un matériel en bon état. Réparer ou remplacer sur-le-champ les pièces endommagées. Entretenir l'appareil conformément à ce manuel.
- Porter un harnais de sécurité si l'on doit travailler au-dessus du sol.
- S'assurer que tous les panneaux et couvercles sont correctement en place.
- Fixer le câble de retour de façon à obtenir un bon contact métal-métal avec la pièce à souder ou la table de travail, le plus près possible de la soudure.
- Isoler la pince de masse quand pas mis à la pièce pour éviter le contact avec tout objet métallique.
- Ne pas raccorder plus d'une électrode ou plus d'un câble de masse à une même borne de sortie de soudage. Débrancher le câble pour le procédé non utilisé.
- Utiliser une protection différentielle lors de l'utilisation d'un équipement auxiliaire dans des endroits humides ou mouillés.

### Il reste une TENSION DC NON NÉGLIGEABLE dans les sources de soudage onduleur UNE FOIS l'alimentation coupée.

- Éteignez l'unité, débranchez le courant électrique, et déchargez les condensateurs d'alimentation selon les instructions indiquées dans le manuel avant de toucher les pièces.



### LES PIÈCES CHAUDES peuvent provoquer des brûlures.

- Ne pas toucher à mains nues les parties chaudes.
- Prévoir une période de refroidissement avant de travailler à l'équipement.

- Ne pas toucher aux pièces chaudes, utiliser les outils recommandés et porter des gants de soudage et des vêtements épais pour éviter les brûlures.



### LES FUMÉES ET LES GAZ peuvent être dangereux.

Le soudage génère des fumées et des gaz. Leur inhalation peut être dangereux pour votre santé.

- Eloigner votre tête des fumées. Ne pas respirer les fumées.
- À l'intérieur, ventiler la zone et/ou utiliser une ventilation forcée au niveau de l'arc pour l'évacuation des fumées et des gaz de soudage. Pour déterminer la bonne ventilation, il est recommandé de procéder à un prélèvement pour la composition et la quantité de fumées et de gaz auxquelles est exposé le personnel.
- Si la ventilation est médiocre, porter un respirateur anti-vapeurs approuvé.
- Lire et comprendre les fiches de données de sécurité et les instructions du fabricant concernant les adhésifs, les revêtements, les nettoyants, les consommables, les produits de refroidissement, les dégraissseurs, les flux et les métaux.
- Travailler dans un espace fermé seulement s'il est bien ventilé ou en portant un respirateur à alimentation d'air. Demander toujours à un surveillant dûment formé de se tenir à proximité. Des fumées et des gaz de soudage peuvent déplacer l'air et abaisser le niveau d'oxygène provoquant des blessures ou des accidents mortels. S'assurer que l'air de respiration ne présente aucun danger.
- Ne pas souder dans des endroits situés à proximité d'opérations de dégraissage, de nettoyage ou de pulvérisation. La chaleur et les rayons de l'arc peuvent réagir en présence de vapeurs et former des gaz hautement toxiques et irritants.
- Ne pas souder des métaux munis d'un revêtement, tels que l'acier galvanisé, plaqué en plomb ou au cadmium à moins que le revêtement n'ait été enlevé dans la zone de soudure, que l'endroit soit bien ventilé, et en portant un respirateur à alimentation d'air. Les revêtements et tous les métaux renfermant ces éléments peuvent dégager des fumées toxiques en cas de soudage.



### LES RAYONS DE L'ARC peuvent provoquer des brûlures dans les yeux et sur la peau.

Le rayonnement de l'arc du procédé de soudage génère des rayons visibles et invisibles intenses (ultraviolets et infrarouges) susceptibles de provoquer des brûlures dans les yeux et sur la peau. Des étincelles sont projetées pendant le soudage.

- Porter un casque de soudage approuvé muni de verres filtrants appropriés pour protéger visage et yeux pour protéger votre visage et vos yeux pendant le soudage ou pour regarder (voir ANSI Z49.1 et Z87.1 énuméré dans les normes de sécurité).
- Porter des lunettes de sécurité avec écrans latéraux même sous votre casque.
- Avoir recours à des écrans protecteurs ou à des rideaux pour protéger les autres contre les rayonnements les éblouissements et les étincelles ; prévenir toute personne sur les lieux de ne pas regarder l'arc.
- Porter un équipement de protection pour le corps fait d'un matériau résistant et ignifuge (cuir, coton robuste, laine). La protection du corps comporte des vêtements sans huile comme par ex. des gants de cuir, une chemise solide, des pantalons sans revers, des chaussures hautes et une casquette.

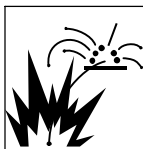

### LE SOUDAGE peut provoquer un incendie ou une explosion.

Le soudage effectué sur des conteneurs fermés tels que des réservoirs, tambours ou des conduites peut provoquer leur éclatement. Des étincelles peuvent être projetées de l'arc de soudure. La projection d'étincelles, des pièces chaudes et des équipements chauds peut provoquer des incendies et des brûlures. Le contact accidentel de l'électrode avec des objets métalliques peut provoquer des étincelles, une explosion, un surchauffement ou un incendie. Avant de commencer le soudage, vérifier et s'assurer que l'endroit ne présente pas de danger.

- Déplacer toutes les substances inflammables à une distance de 10,7 m de l'arc de soudage. En cas d'impossibilité les recouvrir soigneusement avec des protections homologués.
- Ne pas souder dans un endroit où des étincelles peuvent tomber sur des substances inflammables.
- Se protéger et d'autres personnes de la projection d'étincelles et de métal chaud.
- Des étincelles et des matériaux chauds du soudage peuvent facilement passer dans d'autres zones en traversant de petites fissures et des ouvertures.
- Surveiller tout déclenchement d'incendie et tenir un extincteur à proximité.
- Le soudage effectué sur un plafond, plancher, paroi ou séparation peut déclencher un incendie de l'autre côté.
- Ne pas couper ou souder des jantes ou des roues. Les pneus peuvent exploser s'ils sont chauffés. Les jantes et les roues réparées peuvent défaillir. Voir OSHA 29 CFR 1910.177 énuméré dans les normes de sécurité.
- Ne pas effectuer le soudage sur des conteneurs fermés tels que des réservoirs, tambours, ou conduites, à moins qu'ils n'aient été préparés correctement conformément à AWS F4.1 et AWS A6.0 (voir les Normes de Sécurité).
- Ne pas souder là où l'air ambiant pourrait contenir des poussières, gaz ou émanations inflammables (vapeur d'essence, par exemple).
- Brancher le câble de masse sur la pièce la plus près possible de la zone de soudage pour éviter le transport du courant sur une longue distance par des chemins inconnus éventuels en provoquant des risques d'électrocution, d'étincelles et d'incendie.
- Ne pas utiliser le poste de soudage pour dégeler des conduites gelées.
- En cas de non utilisation, enlever la baguette d'électrode du porte-électrode ou couper le fil à la pointe de contact.
- Porter un équipement de protection pour le corps fait d'un matériau résistant et ignifuge (cuir, coton robuste, laine). La protection du corps comporte des vêtements sans huile comme par ex. des gants de cuir, une chemise solide, des pantalons sans revers, des chaussures hautes et une casquette.
- Avant de souder, retirer toute substance combustible de vos poches telles qu'un allumeur au butane ou des allumettes.
- Une fois le travail achevé, assurez-vous qu'il ne reste aucune trace d'étincelles incandescentes ni de flammes.
- Utiliser exclusivement des fusibles ou coupe-circuits appropriés. Ne pas augmenter leur puissance; ne pas les ponter.
- Suivre les recommandations dans OSHA 1910.252(a)(2)(iv) et NFPA 51B pour les travaux à chaud et avoir de la surveillance et un extincteur à proximité.
- Lire et comprendre les fiches de données de sécurité et les instructions du fabricant concernant les adhésifs, les revêtements, les nettoyants, les consommables, les produits de refroidissement, les dégraissseurs, les flux et les métaux.

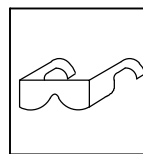

### DES PIÈCES DE METAL ou DES SALETES peuvent provoquer des blessures dans les yeux.

- Le soudage, l'écaillage, le passage de la pièce à la brosse en fil de fer, et le meulage génèrent des étincelles et des particules métalliques volantes. Pendant la période de refroidissement des soudures, elles risquent de projeter du laitier.
- Porter des lunettes de sécurité avec écrans latéraux ou un écran facial.



### LES ACCUMULATIONS DE GAZ risquent de provoquer des blessures ou même la mort.

- Fermer l'alimentation du gaz comprimé en cas de non utilisation.
- Veiller toujours à bien aérer les espaces confinés ou se servir d'un respirateur d'adduction d'air homologué.



### Les CHAMPS ÉLECTROMAGNÉTIQUES (CEM) peuvent affecter les implants médicaux.

- Les porteurs de stimulateurs cardiaques et autres implants médicaux doivent rester à distance.
- Les porteurs d'implants médicaux doivent consulter leur médecin et le fabricant du dispositif avant de s'approcher de la zone où se déroule du soudage à l'arc, du soudage par points, du gougeage, de la découpe plasma ou une opération de chauffage par induction.

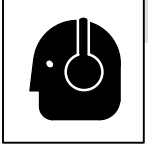

### LE BRUIT peut endommager l'ouïe.

Le bruit des processus et des équipements peut affecter l'ouïe.

- Porter des protections approuvées pour les oreilles si le niveau sonore est trop élevé.



### LES BOUTEILLES peuvent exploser si elles sont endommagées.

Les bouteilles de gaz comprimé contiennent du gaz sous haute pression. Si une bouteille est endommagée, elle peut exploser. Du fait que

les bouteilles de gaz font normalement partie du procédé de soudage, les manipuler avec précaution.

- Protéger les bouteilles de gaz comprimé d'une chaleur excessive, des chocs mécaniques, des dommages physiques, du laitier, des flammes ouvertes, des étincelles et des arcs.
- Placer les bouteilles debout en les fixant dans un support stationnaire ou dans un porte-bouteilles pour les empêcher de tomber ou de se renverser.
- Tenir les bouteilles éloignées des circuits de soudage ou autres circuits électriques.
- Ne jamais placer une torche de soudage sur une bouteille à gaz.
- Une électrode de soudage ne doit jamais entrer en contact avec une bouteille.
- Ne jamais souder une bouteille pressurisée – risque d'explosion.
- Utiliser seulement des bouteilles de gaz comprimé, régulateurs, tuyaux et raccords convenables pour cette application spécifique; les maintenir ainsi que les éléments associés en bon état.
- Tourner le dos à la sortie de vanne lors de l'ouverture de la vanne de la bouteille. Ne pas se tenir devant ou derrière le régulateur lors de l'ouverture de la vanne.
- Le couvercle du détendeur doit toujours être en place, sauf lorsque la bouteille est utilisée ou qu'elle est reliée pour usage ultérieur.
- Utilisez les équipements corrects, les bonnes procédures et suffisamment de personnes pour soulever, déplacer et transporter les bouteilles.
- Lire et suivre les instructions sur les bouteilles de gaz comprimé, l'équipement connexe et le dépliant P-1 de la CGA (Compressed Gas Association) mentionné dans les principales normes de sécurité.

## 2-3. Dangers supplémentaires en relation avec l'installation, le fonctionnement et la maintenance



### Risque D'INCENDIE OU D'EXPLOSION.

- Ne pas placer l'appareil sur, au-dessus ou à proximité de surfaces inflammables.
- Ne pas installer l'appareil à proximité de produits inflammables.
- Ne pas surcharger l'installation électrique – s'assurer que l'alimentation est correctement dimensionnée et protégée avant de mettre l'appareil en service.



### LA CHUTE DE L'ÉQUIPEMENT peut provoquer des blessures.

- Utiliser l'anneau de levage uniquement pour soulever l'appareil, NON PAS les chariots, les bouteilles de gaz ou tout autre accessoire.
- Utilisez les procédures correctes et des équipements d'une capacité appropriée pour soulever et supporter l'appareil.
- En utilisant des fourches de levage pour déplacer l'unité, s'assurer que les fourches sont suffisamment longues pour dépasser du côté opposé de l'appareil.
- Tenir l'équipement (câbles et cordons) à distance des véhicules mobiles lors de toute opération en hauteur.
- Suivre les consignes du Manuel des applications pour l'équation de levage NIOSH révisée (Publication N°94-110) lors du levage manuel de pièces ou équipements lourds.

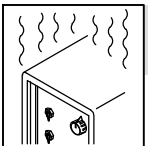

### L'EMPLOI EXCESSIF peut SURCHAUFFER L'ÉQUIPEMENT.

- Prévoir une période de refroidissement ; respecter le cycle opératoire nominal.
- Réduire le courant ou le facteur de marche avant de poursuivre le soudage.
- Ne pas obstruer les passages d'air du poste.

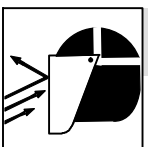

### LES ÉTINCELLES PROJÉTÉES peuvent provoquer des blessures.

- Porter un écran facial pour protéger le visage et les yeux.
- Affûter l'électrode au tungstène uniquement à la meuleuse dotée de protecteurs. Cette manœuvre est à exécuter dans un endroit sûr lorsque l'on porte l'équipement homologué de protection du visage, des mains et du corps.
- Les étincelles risquent de causer un incendie – éloigner toute substance inflammable.

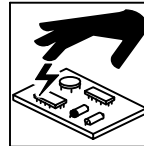

### LES CHARGES ÉLECTROSTATIQUES peuvent endommager les circuits imprimés.

- Établir la connexion avec la barrette de terre avant de manipuler des cartes ou des pièces.
- Utiliser des pochettes et des boîtes antistatiques pour stocker, déplacer ou expédier des cartes de circuits imprimés.

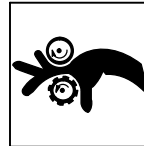

### Les PIÈCES MOBILES peuvent causer des blessures.

- Ne pas s'approcher des organes mobiles.
- Ne pas s'approcher des points de coincement tels que des rouleaux de commande.



### LES FILS DE SOUDAGE peuvent provoquer des blessures.

- Ne pas appuyer sur la gâchette avant d'en avoir reçu l'instruction.
- Ne pas diriger le pistolet vers soi, d'autres personnes ou toute pièce mécanique en engageant le fil de soudage.

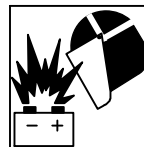

### L'EXPLOSION DE LA BATTERIE peut provoquer des blessures.

- Ne pas utiliser l'appareil de soudage pour charger des batteries ou faire démarrer des véhicules à l'aide de câbles de démarrage, sauf si l'appareil dispose d'une fonctionnalité de charge de batterie destinée à cet usage.



### Les PIÈCES MOBILES peuvent causer des blessures.

- S'abstenir de toucher des organes mobiles tels que des ventilateurs.
- Maintenir fermés et verrouillés les portes, panneaux, recouvrements et dispositifs de protection.
- Lorsque cela est nécessaire pour des travaux d'entretien et de dépannage, faire retirer les portes, panneaux, recouvrements ou dispositifs de protection uniquement par du personnel qualifié.
- Remettre les portes, panneaux, recouvrements ou dispositifs de protection quand l'entretien est terminé et avant de rebrancher l'alimentation électrique.

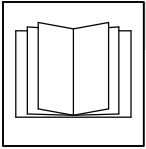

## LIRE LES INSTRUCTIONS.

- Lire et appliquer les instructions sur les étiquettes et le Mode d'emploi avant l'installation, l'utilisation ou l'entretien de l'appareil. Lire les informations de sécurité au début du manuel et dans chaque section.

- N'utiliser que les pièces de rechange recommandées par le constructeur.
- Effectuer l'installation, l'entretien et toute intervention selon les manuels d'utilisateurs, les normes nationales, provinciales et de l'industrie, ainsi que les codes municipaux.

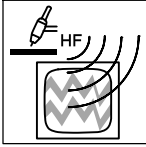

## LE RAYONNEMENT HAUTE FRÉQUENCE (H.F.) risque de provoquer des interférences.

- Le rayonnement haute fréquence (H.F.) peut provoquer des interférences avec les équipements de radio-navigation et de communication, les services de sécurité et les ordinateurs.
- Demander seulement à des personnes qualifiées familiarisées avec des équipements électroniques de faire fonctionner l'installation.
- L'utilisateur est tenu de faire corriger rapidement par un électricien qualifié les interférences résultant de l'installation.
- Si le FCC signale des interférences, arrêter immédiatement l'appareil.

- Effectuer régulièrement le contrôle et l'entretien de l'installation.
- Maintenir soigneusement fermés les portes et les panneaux des sources de haute fréquence, maintenir les éclateurs à une distance correcte et utiliser une terre et un blindage pour réduire les interférences éventuelles.



## LE SOUDAGE À L'ARC risque de provoquer des interférences.

- L'énergie électromagnétique risque de provoquer des interférences pour l'équipement électronique sensible tel que les ordinateurs et l'équipement commandé par ordinateur tel que les robots.
- Veiller à ce que tout l'équipement de la zone de soudage soit compatible électromagnétiquement.
- Pour réduire la possibilité d'interférence, maintenir les câbles de soudage aussi courts que possible, les grouper, et les poser aussi bas que possible (ex. par terre).
- Veiller à souder à une distance de 100 mètres de tout équipement électronique sensible.
- Veiller à ce que ce poste de soudage soit posé et mis à la terre conformément à ce mode d'emploi.
- En cas d'interférences après avoir pris les mesures précédentes, il incombe à l'utilisateur de prendre des mesures supplémentaires telles que le déplacement du poste, l'utilisation de câbles blindés, l'utilisation de filtres de ligne ou la pose de protecteurs dans la zone de travail.

## 2-4. Proposition californienne 65 Avertissements

**⚠ AVERTISSEMENT : ce produit peut vous exposer à des produits chimiques tels que le plomb, reconnus par l'État de Californie comme cancérigènes et sources de malformations ou d'autres troubles de la reproduction.**

Pour plus d'informations, consulter [www.P65Warnings.ca.gov](http://www.P65Warnings.ca.gov).

## 2-5. Principales normes de sécurité

*Safety in Welding, Cutting, and Allied Processes*, ANSI Standard Z49.1, is available as a free download from the American Welding Society at <http://www.aws.org> or purchased from Global Engineering Documents (phone: 1-877-413-5184, website: [www.global.ihc.com](http://www.global.ihc.com)).

*Safe Practices for the Preparation of Containers and Piping for Welding and Cutting*, American Welding Society Standard AWS F4.1, from Global Engineering Documents (phone: 1-877-413-5184, website: [www.global.ihc.com](http://www.global.ihc.com)).

*Safe Practices for Welding and Cutting Containers that have Held Combustibles*, American Welding Society Standard AWS A6.0, from Global Engineering Documents (phone: 1-877-413-5184, website: [www.global.ihc.com](http://www.global.ihc.com)).

*National Electrical Code*, NFPA Standard 70, from National Fire Protection Association, Quincy, MA 02169 (phone: 1-800-344-3555, website: [www.nfpa.org](http://www.nfpa.org) and [www.sparky.org](http://www.sparky.org)).

*Safe Handling of Compressed Gases in Cylinders*, CGA Pamphlet P-1, from Compressed Gas Association, 14501 George Carter Way, Suite 103, Chantilly, VA 20151 (phone: 703-788-2700, website: [www.cganet.com](http://www.cganet.com)).

*Safety in Welding, Cutting, and Allied Processes*, CSA Standard W117.2, from Canadian Standards Association, Standards Sales, 5060 Spec-

trum Way, Suite 100, Mississauga, Ontario, Canada L4W 5N5 (phone: 800-463-6727, website: [www.csagroup.org](http://www.csagroup.org)).

*Safe Practice For Occupational And Educational Eye And Face Protection*, ANSI Standard Z87.1, from American National Standards Institute, 25 West 43rd Street, New York, NY 10036 (phone: 212-642-4900, website: [www.ansi.org](http://www.ansi.org)).

*Standard for Fire Prevention During Welding, Cutting, and Other Hot Work*, NFPA Standard 51B, from National Fire Protection Association, Quincy, MA 02169 (phone: 1-800-344-3555, website: [www.nfpa.org](http://www.nfpa.org)). OSHA, Occupational Safety and Health Standards for General Industry, Title 29, Code of Federal Regulations (CFR), Part 1910.177 Subpart N, Part 1910 Subpart Q, and Part 1926, Subpart J, from U.S. Government Printing Office, Superintendent of Documents, P.O. Box 371954, Pittsburgh, PA 15250-7954 (phone: 1-866-512-1800) (there are 10 OSHA Regional Offices—phone for Region 5, Chicago, is 312-353-2220, website: [www.osha.gov](http://www.osha.gov)).

*Applications Manual for the Revised NIOSH Lifting Equation*, The National Institute for Occupational Safety and Health (NIOSH), 1600 Clifton Rd, Atlanta, GA 30329-4027 (phone: 1-800-232-4636, website: [www.cdc.gov/NIOSH](http://www.cdc.gov/NIOSH)).

## 2-6. Informations relatives aux CEM

Le courant électrique qui traverse tout conducteur génère des champs électromagnétiques (CEM) à certains endroits. Le courant issu d'un soudage à l'arc (et de procédés connexes, y compris le soudage par points, le gougeage, le découpage plasma et les opérations de chauffage par induction) crée un champ électromagnétique (CEM) autour du circuit de soudage. Les champs électromagnétiques produits peuvent causer interférence à certains implants médicaux, p. ex. les stimulateurs cardiaques. Des mesures de protection pour les porteurs d'implants médicaux doivent être prises: Limiter par exemple tout accès aux passants ou procéder à une évaluation des risques individuels pour les soudeurs. Tous les soudeurs doivent appliquer les procédures suivantes pour minimiser l'exposition aux CEM provenant du circuit de soudage:

1. Rassembler les câbles en les torsadant ou en les attachant avec du ruban adhésif ou avec une housse.
2. Ne pas se tenir au milieu des câbles de soudage. Disposer les

câbles d'un côté et à distance de l'opérateur.

3. Ne pas courber et ne pas entourer les câbles autour de votre corps.
4. Maintenir la tête et le torse aussi loin que possible du matériel du circuit de soudage.
5. Connecter la pince sur la pièce aussi près que possible de la soudure.
6. Ne pas travailler à proximité d'une source de soudage, ni s'asseoir ou se pencher dessus.
7. Ne pas souder tout en portant la source de soudage ou le dévidoir.







### En ce qui concerne les implants médicaux :

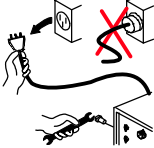

Les porteurs d'implants doivent d'abord consulter leur médecin avant de s'approcher des opérations de soudage à l'arc, de soudage par points, de gougeage, du coupage plasma ou de chauffage par induction. Si le médecin approuve, il est recommandé de suivre les procédures précédentes.

# SECTION 3 – DEFINITIONS

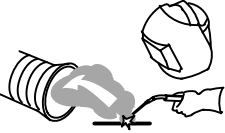
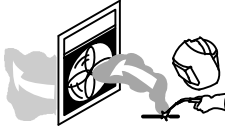
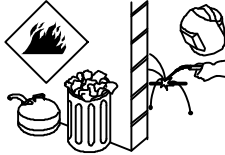
## 3-1. Additional Safety Symbols And Definitions





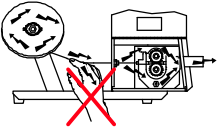
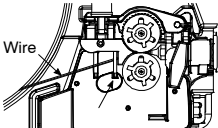
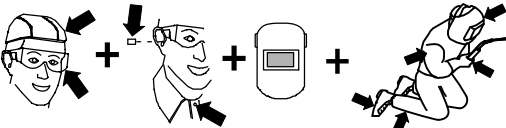
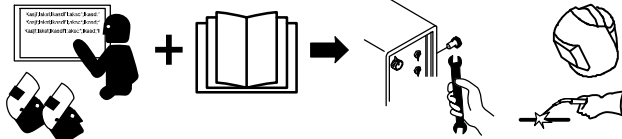



 Some symbols are found only on CE products.









	<p>Warning! Watch Out! There are possible hazards as shown by the symbols.</p> <p style="text-align: right;">Safe1 2012-05</p>
	<p>Wear dry insulating gloves. Do not touch electrode with bare hand. Do not wear wet or damaged gloves.</p> <p style="text-align: right;">Safe2 2017-04</p>
	<p>Protect yourself from electric shock by insulating yourself from work and ground.</p> <p style="text-align: right;">Safe3 2017-04</p>
	<p>Disconnect input plug or power before working on machine.</p> <p style="text-align: right;">Safe5 2017-04</p>
	<p>Keep your head out of the fumes.</p> <p style="text-align: right;">Safe6 2017-04</p>
	<p>Use forced ventilation or local exhaust to remove the fumes.</p> <p style="text-align: right;">Safe60 2012-06</p>
	<p>Use ventilating fan to remove fumes.</p> <p style="text-align: right;">Safe61 2012-06</p>
	<p>Keep flammables away from welding. Do not weld near flammables.</p> <p style="text-align: right;">Safe62 2012-06</p>
	<p>Welding sparks can cause fires. Have a fire extinguisher nearby, and have a watchperson ready to use it.</p> <p style="text-align: right;">Safe63 2012-06</p>





	Do not weld on drums or any closed containers.	Safe16 2017-04
	Do not remove or paint over (cover) the label.	Safe20 2017-04
	Welding wire and drive parts are at welding voltage during operation – keep hands and metal objects away.	Safe33 2017-04
 Wire	Feed wire between guide pins into drive rolls.	Safe124 2017-02
	Wear hat and safety glasses. Use ear protection and button shirt collar. Use welding helmet with correct shade of filter. Wear complete body protection.	Safe66 2012-06
	Become trained and read the instructions before working on the machine or welding.	Safe65 2012-06

### 3-2. Miscellaneous Symbols And Definitions

 Some symbols are found only on CE products.

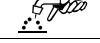
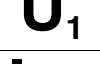
	On
	Percent
	Purge By Gas
	Constant Voltage
	Rated Welding Current
	Off
	Run-In
	Filter

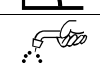
	Amperes
	Volts
	Degree Of Protection
	Line Connection
	Gas IN
	Increase
	Wire Feed
	Cold Jog (Inch) Toward Workpiece

	Supplementary Protector
	Trigger Hold On
	Input Voltage
	Input Current
	Input
	Constant Current
	Trigger Hold Off
	Read Instructions

# SECTION 4 – SPECIFICATIONS

## 4-1. Serial Number And Rating Label Location

The serial number and rating information for this product is located inside the door. Use rating label to determine input power requirements and/or rated output. For future reference, write serial number in space provided on back cover of this manual.

## 4-2. Unit Specifications

Type of Input Power	Welding Power Source Type	Wire Feed Speed*	Wire Diameter Range	Input Welding Circuit Rating	Max. Wire Spool Capacity	Overall Dimensions	Weight
Open-Circuit/ Arc Voltage, 14 – 110 Volts DC	Constant Voltage (CV) Or Constant Current (CC) DC Power Source Only	25 – 800 ipm (0.64 – 20.3 mpm) Depending On Arc Voltage	Solid Wire: .023 - .052 in. (0.6 To 1.3 mm)  Flux Cored: .030 - 5/64 in. (0.8 To 2 mm)	425 Amperes At 60% Duty Cycle  300 Amperes At 100% Duty Cycle	45 lb (20.4 kg), 12 in. (304 mm)	Length: 21 in. (533 mm)  Width: 9 in. (229 mm)  Height: 15-1/2 in. (394 mm)	34.5 lb (15.6 kg)

\*See Section 4-4 for detailed wire type, size, and rated speed range

## 4-3. Environmental Specifications

### A. IP Rating

IP Rating
IP23 This equipment is designed for outdoor use.

IP23 2017-02

### B. Temperature Specifications

Operating Temperature Range	Storage Temperature Range
14 to 104°F (-10 to 40°C)	-4 to 131°F (-20 to 55°C)

Temp\_2016-07

## 4-4. Wire Type, Size, and Feed Speed Capability Table

Motor Speed	Wire Type	Wire Size	Rated Speed Range*
Standard	All	Solid Wire: .023 - .052 in. (0.6 To 1.3 mm)  Flux Cored: .030 - 5/64 in. (0.8 To 2 mm)	50 to 780 ipm (1.3 -19.8 mpm)

\*Rated speed range per IEC 60974-5

## 4-5. Gun Recommendation Table

Process	Gun
GMAW – Hard or Cored Wires	Bernard Q-Gun, S-Gun Tregaskiss Tough Gun Roughneck C-Series
FCAW – Self-Shielding Wires	Bernard Dura-Flux Gun Ironmate Series

# SECTION 5 – INSTALLATION

## 5-1. Equipment Connection Diagram

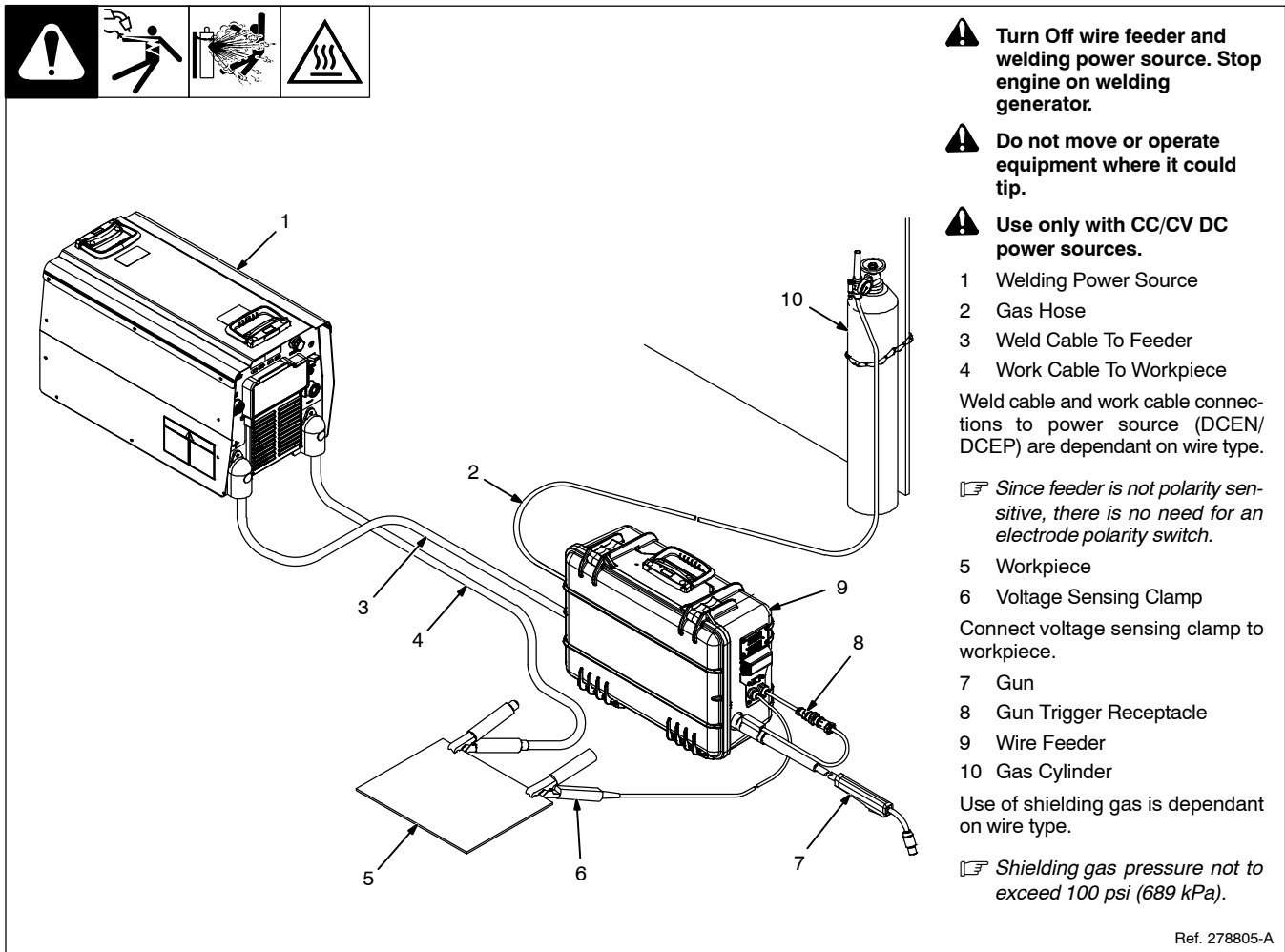

## 5-2. ArcReach Applications

- ☞ To take advantage of the ArcReach features, the ArcReach wire feeder must be used with an ArcReach Control, or an ArcReach compatible welding power source. The ArcReach wire feeder may also be used as a standard feeder on any Non-ArcReach power source.
- ☞ This wire feeder has the ability to associate with an ArcReach compatible welding power source at power up, or when wire feeder is triggered. For either method, the welding power source must be in an Output On mode. See instructions in the welding power source Owner's Manual.
- ☞ This wire feeder has the Cable Length Compensation feature, see Section 6-2 for details.

## 5-3. Associating Wire Feeder To ArcReach Compatible Power Source Or ArcReach Control

### Associating wire feeder to an ArcReach compatible welding power source at power up

- ☞ The welding power source must be in an Output On mode. See instructions in the welding power source Owner's Manual.
  - ☞ On wire feeder, set CC/CV switch to CV mode. The feeder will not associate with another piece of equipment if the feeder is set to CC mode.
  - ☞ If associating to a Power Source with the Cable Length Compensation feature, see Section 6-2 for details.
- 1 Turn on the welding power source and wire feeder.
  - 2 Decimal points on feeder voltmeter will blink.
  - 3 When decimal points stop blinking and a voltage is displayed, the feeder and power source are associated. The association process may take several seconds to complete.
  - 4 Dependent on the capabilities of the ArcReach power source, the feeder may set the mode switch to the correct wire mode. The wire mode is determined by the polarity of the connections to the feeder.
  - 5 Use voltage control on feeder to adjust preset weld voltage.
  - 6 The voltmeter on the feeder will display preset weld voltage while idle or weld voltage while welding.





## 5-5. Installing Drive Rolls



### Installing Drive Rolls:

- 1 Drive Securing Roll Nut
- 2 Drive Roll Carrier

Turn nut one click until lobes of nut line up with lobes of drive roll carrier.

- 3 Drive Roll

Slide drive roll onto drive roll carrier. Turn nut one click.

Repeat procedure for top drive roll.

### Cleaning Drive Rolls:

Remove drive rolls, and clean grooves using a wire brush.

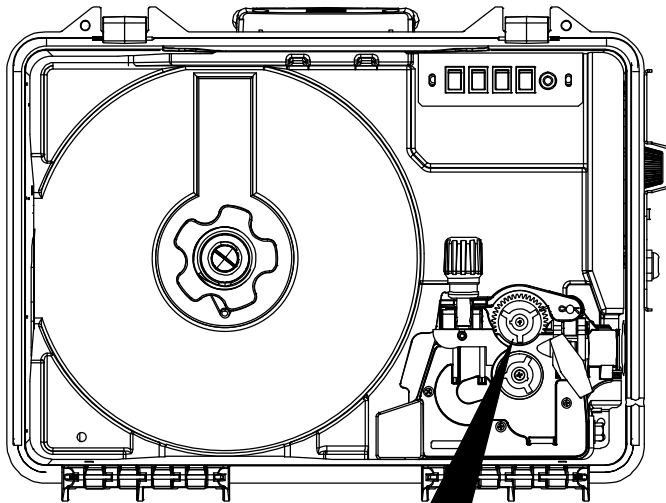

### Installing Drive Rolls

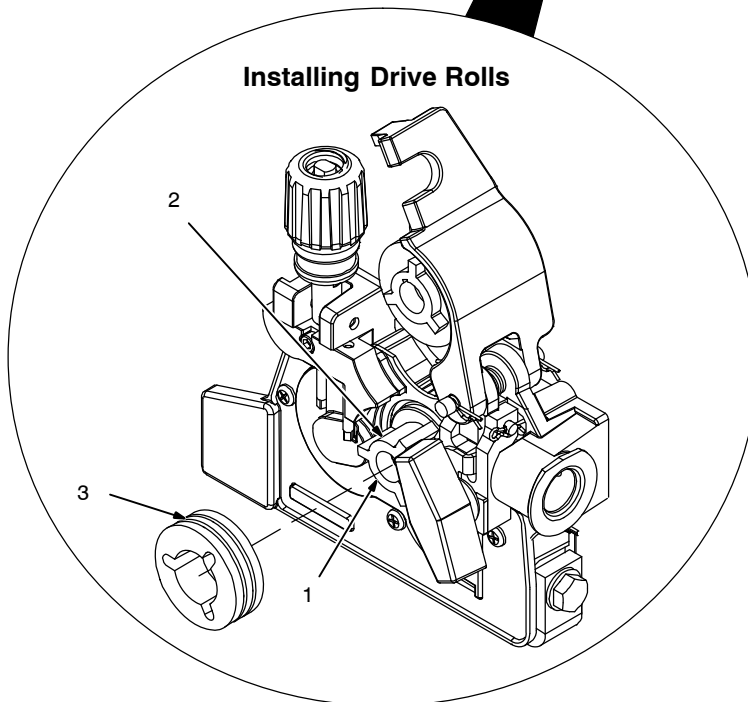

## 5-6. Connecting Welding Gun And Voltage Sensing Clamp

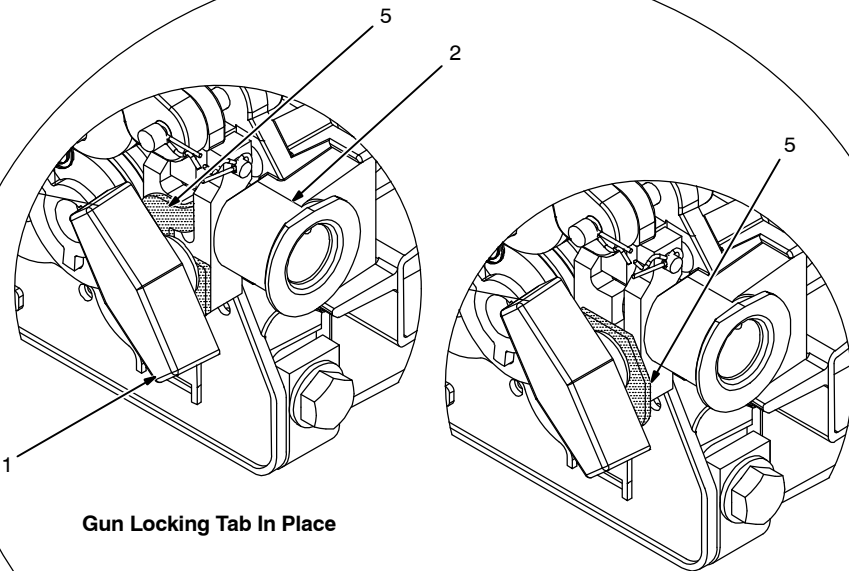

Gun Locking Tab In Place

Gun Locking Tab Out Of Place

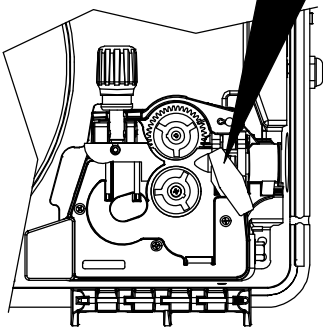

Internal Side View

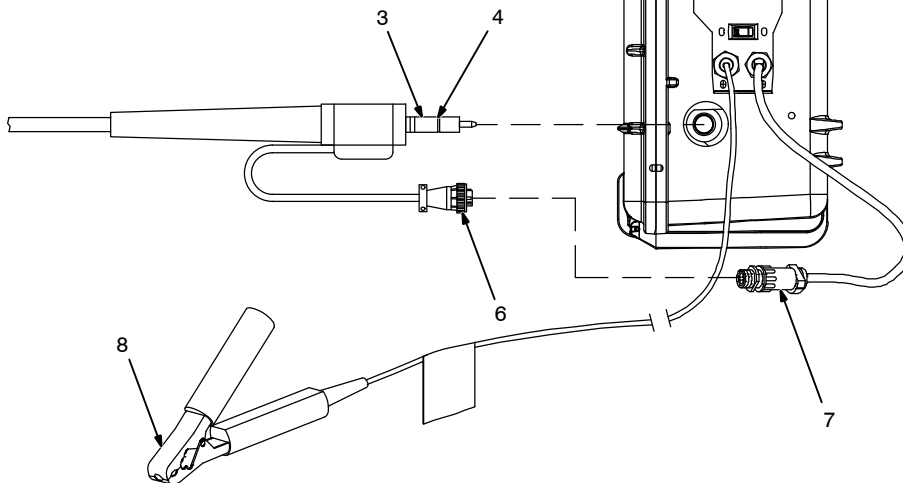

**⚠ Turn Off wire feeder and welding power source. Stop engine on welding generator.**

**⚠ Weld voltage is present at voltage sensing clamp when wire feeder and welding power source are on. This condition exists even if wire feeder light and meters are off.**

**⚠ Turn off wire feeder or welding power source before handling or moving voltage sensing clamp.**

- 1 Gun Securing Knob
- 2 Gun Block
- 3 Gun Power Pin
- 4 Power Pin Groove
- 5 Gun Locking Tab

Loosen gun securing knob, insert gun power pin into gun block. Position power pin as close as possible to drive rolls without touching. Align the gun power pin groove with the gun locking tab. Tighten gun securing knob.

If the gun power pin does not have a groove, loosen knob to rotate the gun locking tab 180 degrees. This prevents the the gun locking tab from interfering with the gun power pin when inserted into the gun block. Insert the gun power pin into the gun block. Position power pin as close as possible to drive rolls without touching them. Tighten gun securing knob.

- 6 Gun Trigger Plug
- 7 Gun Trigger Receptacle

Connect gun trigger plug to gun trigger receptacle.

See Section 6-3 to make wire speed dual schedule connections to gun trigger receptacle.

- 8 Voltage Sensing Clamp
- Connect voltage sensing clamp to workpiece.

## 5-7. Connecting Shielding Gas



**NOTICE** – This feeder has a shielding gas filter that requires special attention when cleaning. See Section 7-3 for proper cleaning instructions.

- 1 Gas Hose With 5/8-18 Right-hand Thread Fittings (Customer Supplied)

Tighten gas hose fitting to a maximum of 100 in. lbs (12 N-m).

- 2 Shielding Gas Cylinder

Shielding gas pressure not to exceed 100 psi (689 kPa).

- 3 Valve

- 4 Flowmeter

Close valve on cylinder when finished welding.

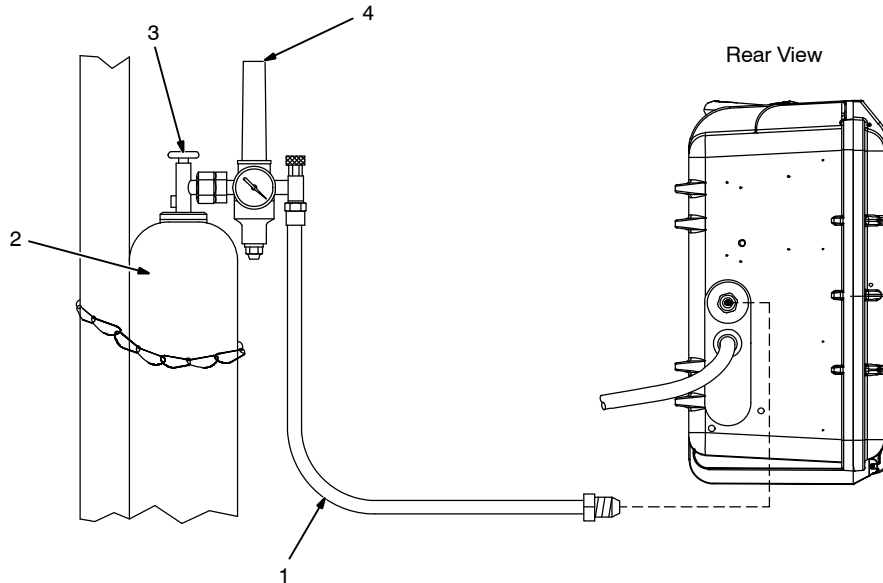

256 620-A

## 5-8. Connecting Weld Cable



Turn off power before connecting to weld terminal or receptacle.

Failure to properly connect weld cables may cause excessive heat and start a fire, or damage your machine.

- 1 User-Supplied Weld Cable

Follow wire manufacturer's recommendations for weld cable polarity.

- 2 Male Connector

- 3 User-Supplied Female Connector

Connect male and female connectors.

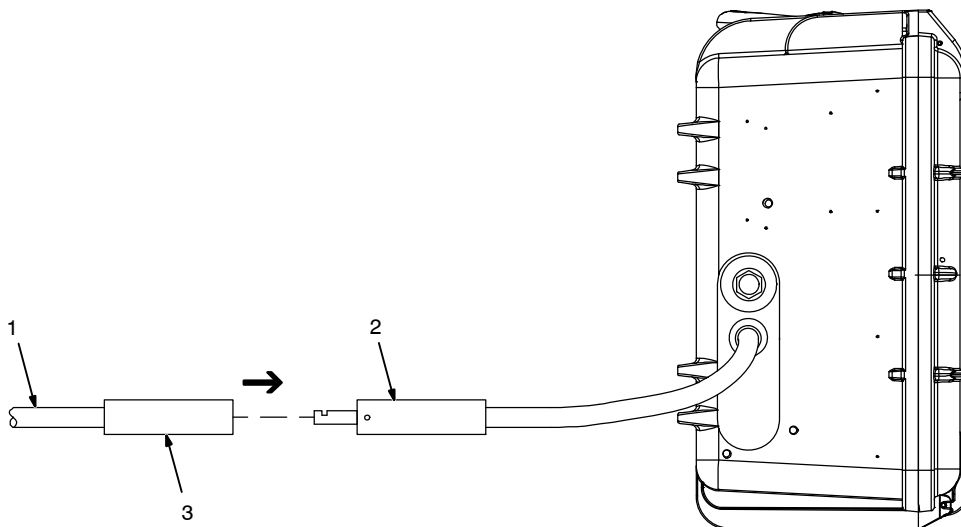

256621-A



## 5-10. Installing And Threading Welding Wire

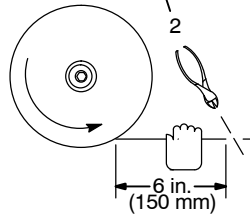
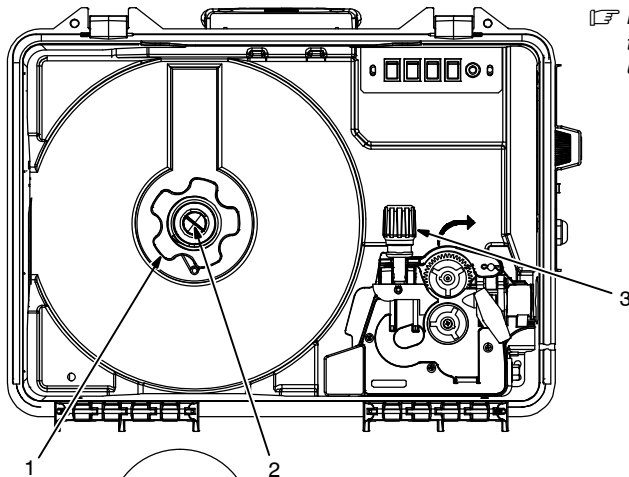
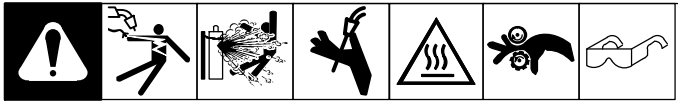

Pull and hold wire; cut off end.

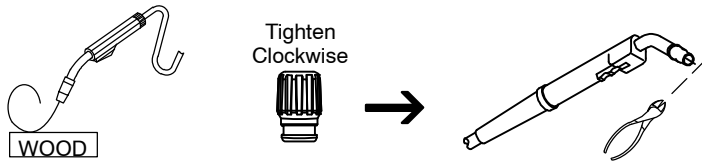

### Installing Wire And Adjusting Hub Tension:

- 1 Retaining Nut
- 2 Hub Tension Adjustment Knob

Remove retaining nut, and install spool so hub pin fits spool hole. Reinstall retaining nut.

Adjust tension knob so only a slight force is needed to turn spool.

*Do not over tighten tension knob. It is not necessary to use any tools to tighten the knob.*

### Threading Welding Wire:

- 3 Pressure Adjustment Knob

Lay gun cable out straight.

Open pressure assembly. Hold wire tightly and cut off end. Guide wire between alignment pins, into drive roll grooves, and into gun liner.

Close pressure assembly and tighten pressure adjustment knob enough to feed wire. Press jog switch until wire comes out of gun.

To set proper drive roll pressure, release the pressure on the drive rolls by loosening the pressure adjustment knob. Position gun at about a 45 degree angle, with nozzle about two inches from a wooden surface. While feeding the wire against the wooden surface, increase the pressure to one half turn past the point where the wire stops slipping. If the wire slips at maximum hand-tight pressure, there may be other problems. Check the gun liner, spool tension, contact tip and drive roll wear, as all these can cause wire feeding problems.

Cut off wire, and close door.

Ref. 257 806-B

## 5-11. Motor Board (PC1) DIP Switch Settings

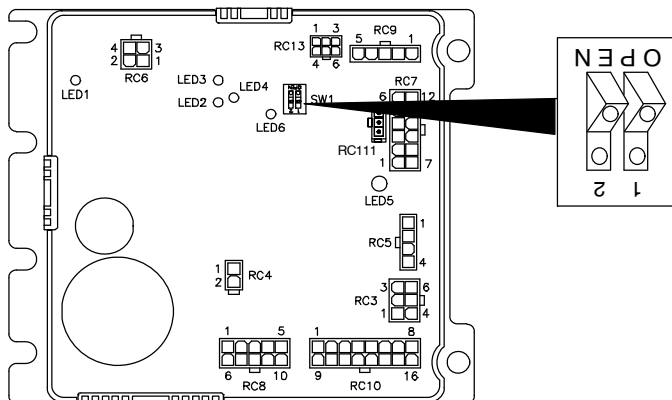
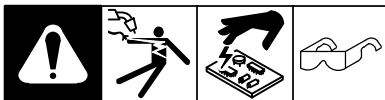

- 1 Motor Control Board PC1
- 2 DIP Switch SW1
- 3 LED5

*DIP switch SW1 is used to match the performance of PC1 to the characteristics of the motor used in the feeder. Setting SW1 as shown will help insure that PC1 and motor are matched for optimal performance.*

If protective coating is present, remove before setting DIP switch. It is not necessary to reapply the protective coating.

Set switch positions 1 and 2 so the depressed section of both tabs are toward 1 and 2 as labeled on the switch. As shown in illustration.

When feeder is powered up, LED 5 on the motor control board will blink four times. This blinking indicates everything is working properly and the DIP switch is set correctly.

After LED 5 is done blinking, it will be either red or green. Red indicates that the feeder is connected with electrode positive. Green indicates feeder is connected with electrode negative.

247 678-B



## 5-12. Meter Board (PC22) DIP Switch Settings

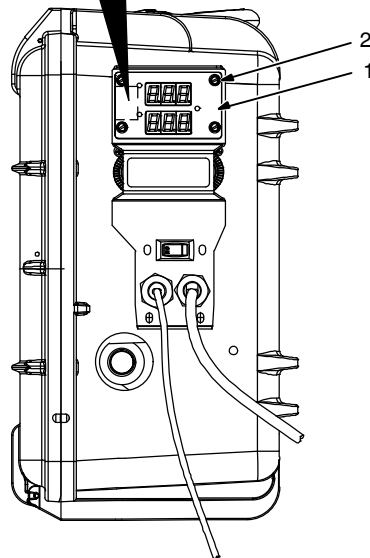
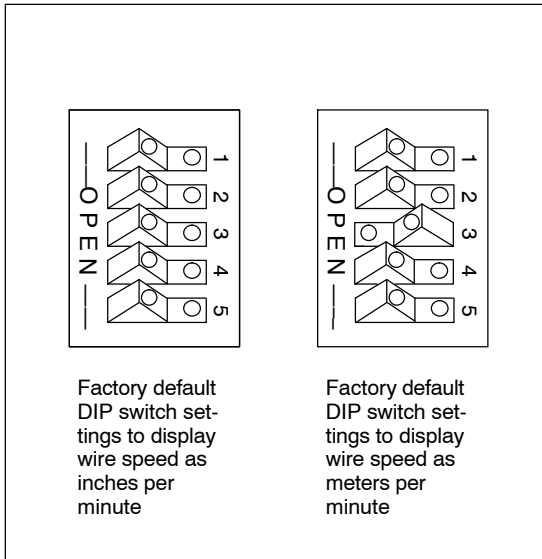

### Accessing DIP Switch

#### 1 Lens

DIP switch is located under the lens next to the displays.

#### 2 Lens Screws

Remove three screws.

Loosen upper right hand screw to rotate lens enough to access DIP switch.

Replace three screws removed earlier.

Tighten upper right hand screw.

*The two upper screws must engage the backing plate to properly secure the front panel.*

### DIP Switch Settings:

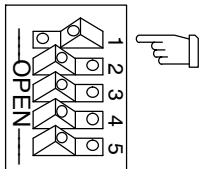

**Display Hold OFF** – Set switch 1 so the depressed section is toward OPEN as labeled on the switch.

Displays will not hold values. The voltage displayed while welding is an average reading over a time span of 6 to 8 seconds. If the weld time is less than 8 seconds, the voltage displayed may not be accurate.

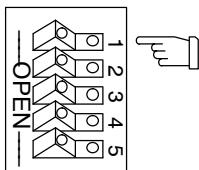

**Display Hold ON (Factory Default)** – Set switch 1 so the depressed section is toward 1 as labeled on the switch.

Displays will hold their last value for five seconds after the trigger is released. The voltage displayed while welding is an average reading over a time span of 6 to 8 seconds. If the weld time is less than 8 seconds, the voltage displayed may not be accurate.



**DIP Switch Settings (continued):**

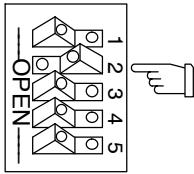

**Display Amperage** – Set switch 2 so the depressed section is toward OPEN as labeled on the switch.

Wire Speed / Amps Display will display Amps while welding and Wire Speed while not welding. If the hold function is enabled, Amps will be displayed during hold also.

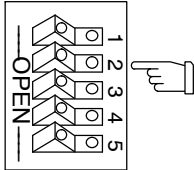

**Do Not Display Amperage (Factory Default)** – Set switch 2 so the depressed section is toward 2 as labeled on the switch.

Wire Speed / Amps Display will display only Wire Speed.

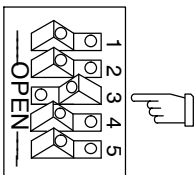

**Wire Speed - Meters Per Minute** – Set switch 3 so the depressed section is toward OPEN as labeled on the switch.

Displays Wire Speed in Meters per Minute.

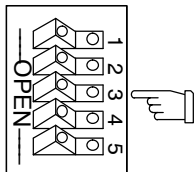

**Wire Speed - Inches Per Minute** – Set switch 3 so the depressed section is toward 3 as labeled on the switch.

Displays Wire Speed in Inches per Minute.

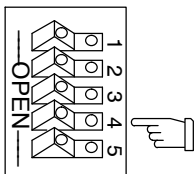

**Wire feeds during ArcReach association (Factory Default)** – Set switch 4 so the depressed section is toward 4 as labeled on the switch.

This will allow wire to feed when the trigger is pulled and the association process is taking place.

This mode must be used when the feeder is not expected to associate with an ArcReach control, or an ArcReach compatible welding power source. This could be when using a non-ArcReach compatible power source or if the feeder CC/CV switch is set to CC mode.

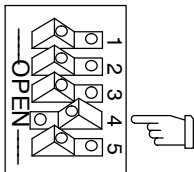

**Wire does not feed during ArcReach association** – Set switch 4 so the depressed section is toward OPEN as labeled on the switch.

This will prevent wire from feeding when the trigger is pulled and the association process is taking place.

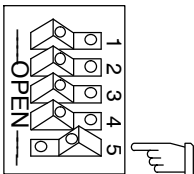

**Display Feeder Information** – Set switch 5 so the depressed section is toward OPEN as labeled on the switch.

With switch in ON position, at feeder power up, feeder will display various sets of information. Each set of information will be displayed for three seconds.

**Display Board (PC22) Software Part Number** –

Top display will show the first three digits, bottom display will show last three digits of the Display board (PC22) software revision level.

**Motor Board (PC1) Software Part Number** –

Top display will show the first three digits, bottom display will show last three digits of the Motor board (PC1) software revision level.

**Accumulated Weld Time** –

This is the time the feeder has actually been used for welding. This information will be displayed in two halves. First half being years (top display) and days (bottom display), second half is hours (top display) and minutes (bottom display).

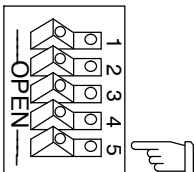

**Do Not Display Feeder Information (Factory Default)** – Set switch 5 so the depressed section is toward 5 as labeled on the switch.

Feeder information is not displayed.

# SECTION 6 – OPERATION

## 6-1. Controls

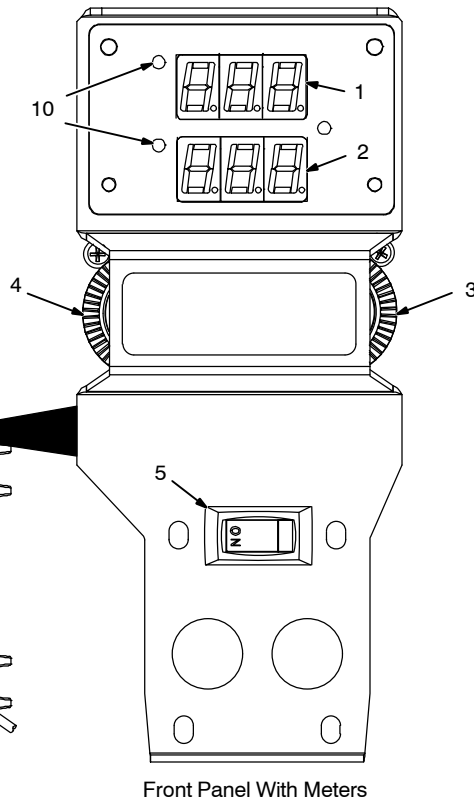

Front Panel With Meters

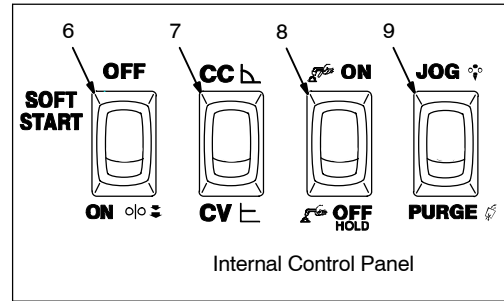

Internal Control Panel

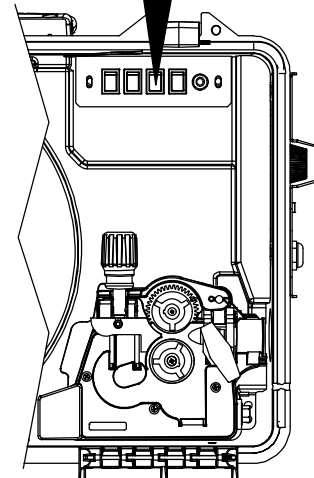

Internal Side View

Ref. 278794-A

### 1 Voltmeter

When not welding and the wire feeder is not associated with the ArcReach compatible welding power source or ArcReach Control, the voltmeter will display three dashes.

If the decimal points on the voltmeter are blinking, the wire feeder is trying to associate to an ArcReach Control or welding power source. See Section 5-4 for details.

When the wire feeder is associated with an ArcReach compatible welding power source or ArcReach Control, the voltmeter will display preset voltage while idle. While welding, the feeder will display the actual weld voltage at the wire feeder.

When connected to a non-ArcReach welding power source, the voltmeter will display three dashes while idle. While welding, the feeder will display the actual weld voltage at the wire feeder.

When the wire feeder is in CC mode, the voltmeter will display CC while idle. While welding, the feeder will display the actual weld voltage at the wire feeder.

Whether the wire feeder is associated or not, the voltage displayed while welding is an average reading over a time span of six to eight seconds. If the weld time is less than eight seconds, the voltage displayed may not be accurate.

### 2 Wire Speed / Amperage Meter

Displays wire speed in inches per minute. Amperage displayed at the feeder is

approximate. Refer to power source for actual amperage.

### 3 Wire Speed Control

Use control to adjust wire speed. Maximum wire speed may be limited by arc voltage.

### 4 Voltage Control

Used to adjust output voltage of welding power source when wire feeder is associated with an ArcReach compatible welding power source or ArcReach Control. Voltage may be adjusted while not welding.

*If using a power source capable of Communication while welding, the voltage may be adjusted while welding.*

Voltage control has no function when the wire feeder is not associated with an ArcReach compatible welding power source or ArcReach Control.

### 5 Power Control Switch

### 6 Soft Start Switch

The Soft Start feature provides a smooth start during most weld conditions. When the trigger is pulled, the wire speed is approximately 50 percent of the weld wire speed, as set by the wire speed control knob. After an arc is established, the wire speed increases to the weld wire speed.

When using small diameter wire, or with inverter power sources, it may be necessary to turn switch off to obtain smooth starts.

### 7 CC/CV Switch

Use switch to match feeder with the output of the power source.

*The feeder will not associate with an ArcReach Control or power source if the switch is set to CC.*

### 8 Trigger Hold Switch

Trigger hold allows operator to weld without holding gun trigger. To use trigger hold function, place trigger hold switch in the ON position.

The operator must hold the trigger for a minimum of two seconds, but no longer than six seconds before releasing it. Welding will continue when trigger is released.

To stop welding, press and release the trigger.

### 9 Jog/Purge Switch

Pressing the Jog switch allows the operator to jog wire without energizing the contactor or gas valve.

Pressing the Purge switch allows the operator to purge gas lines before welding and to preset gas flow rate at the flowmeter.

After adjusting the switches, close and latch the door before welding.

### 10 Polarity Indicators

Indicate whether feeder is connected to the welding power source Electrode Positive (DCEP) or Electrode Negative (DCEN).



### 6-3. Wire Speed Dual Schedule

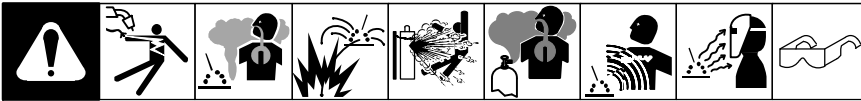

Weld Gun With Internal Mounted Dual Schedule Switch

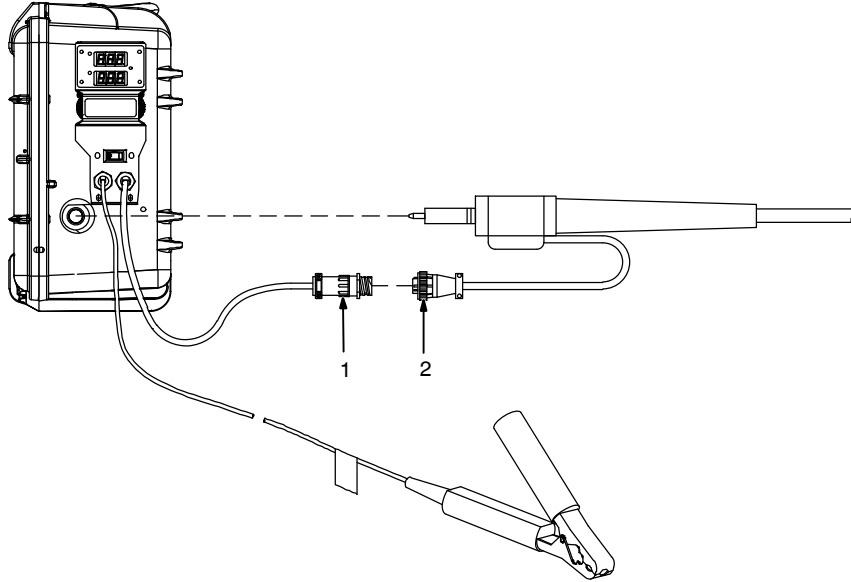

Wire Speed Dual Schedule allows the operator to switch between standard wire speed and a reduced wire speed. When activated, the reduced wire speed will be 87.5% of the standard wire speed. Wire Speed Dual Schedule may be activated any time before or during the weld by using a gun with an internally mounted dual schedule switch, or a gun with an added dual schedule switch. If the feeder is equipped with Wire Speed Meter it will display the active wire speed, whether it is standard wire speed or reduced wire speed.

**Weld Gun With Internal Mounted Dual Schedule Switch** Comparable To PipePro® Dura-Flux™ Gun.

- 1 Gun Trigger Receptacle
- 2 Gun Trigger Plug

Connect gun trigger plug to gun trigger receptacle.

Weld Gun With External Mounted Dual Schedule Switch

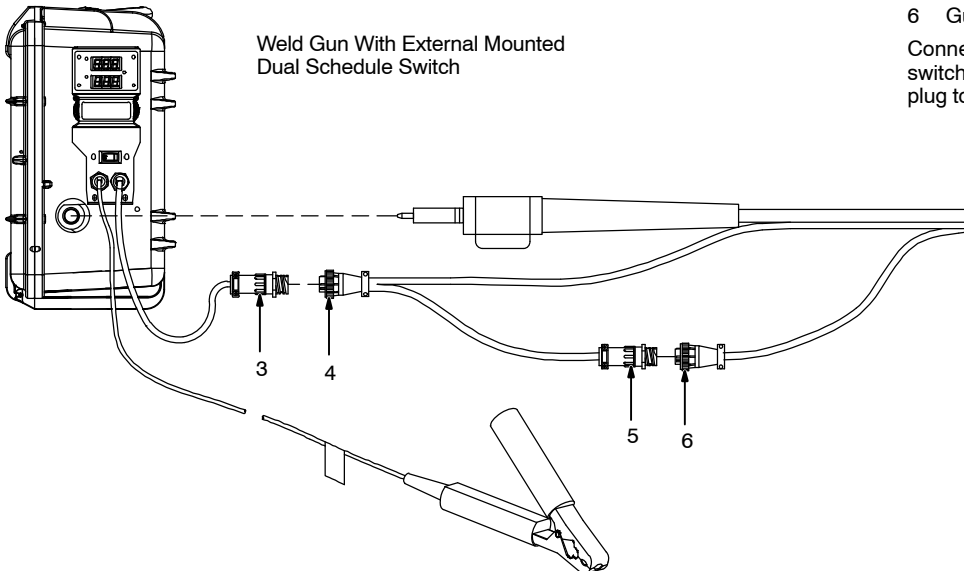

**Weld Gun With External Mounted Dual Schedule Switch** Comparable To DSS-9-15 (071833)





- 3 Gun Trigger Receptacle
- 4 Dual Schedule Plug
- 5 Dual Schedule Switch Receptacle
- 6 Gun Trigger Plug



Connect gun trigger plug to dual schedule switch receptacle . Connect dual schedule plug to gun trigger receptacle.





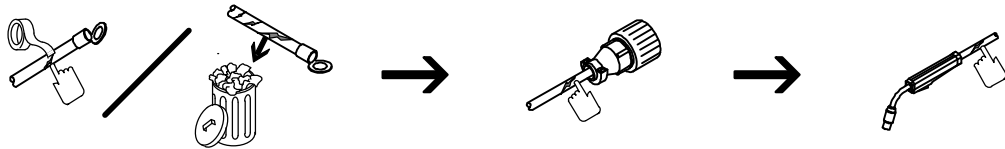
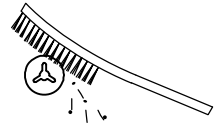
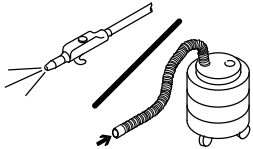

# SECTION 7 – MAINTENANCE & TROUBLESHOOTING

## 7-1. Routine Maintenance

						<p><b>⚠ Disconnect power before maintaining.</b></p> <p> <i>Maintain more often during severe conditions.</i></p>
---	---	---	---	---	---	--

	<p>✓ = Check      ◇ = Change      ● = Clean      ☆ = Replace</p> <p>* To be done by Factory Authorized Service Agent</p>	
<p>Every 3 Months</p>	 <p>☆ Damaged Or Unreadable Labels</p>	 <p>☆ Damaged Gas Hose</p>
	 <p>✓ ☆ Cracked Cables And Cords</p>	
<p>Every 6 Months</p>	 <p>✓ ● Drive Rolls</p>	 <p>● Blow Out Or Vacuum Inside</p>

## 7-2. Overload Protection And Thermostat Protection

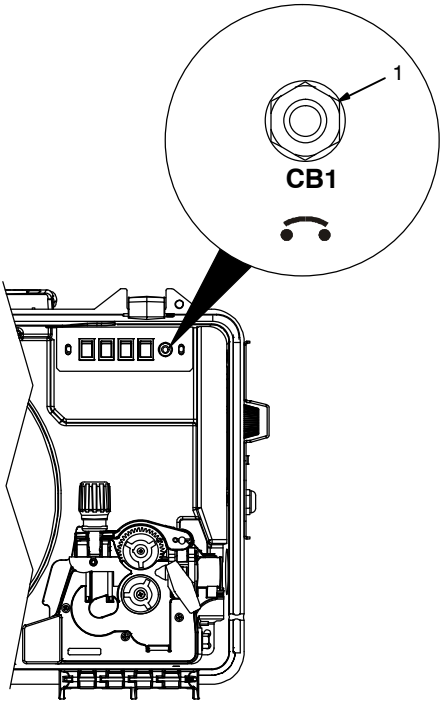
				<p><b>⚠ Turn Off wire feeder and welding power source. Stop engine on welding generator.</b></p> <p>1 Supplementary Protector CB1</p> <p>CB1 protects wire feeder from overload. Correct problem and reset CB1.</p> <p>Close and latch door.</p> <p><b>Thermostat Protection</b></p> <p>Unit has internal thermostat protection and will not feed wire if overheating occurs (see Section 7-4).</p>
 <p>Internal Side View</p>				

Ref. 278794-A

### 7-3. Cleaning Debris From Shielding Gas Filter Fitting



**⚠ Disconnect power before maintaining.**

1 Shielding Gas Filter Fitting  
Remove fitting from gas valve on back panel of feeder.

Blow compressed air through the threaded male end of fitting to dislodge debris from internal mesh screen.

 *Replace fitting if blowing compressed air through fitting does not clear obstructions.*

Reinstall fitting into gas valve.

Tighten fitting to 250 in. lbs (28 N·m).

Rear View of Feeder

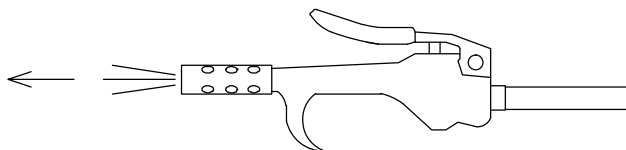
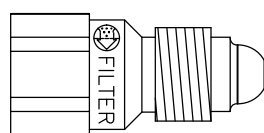
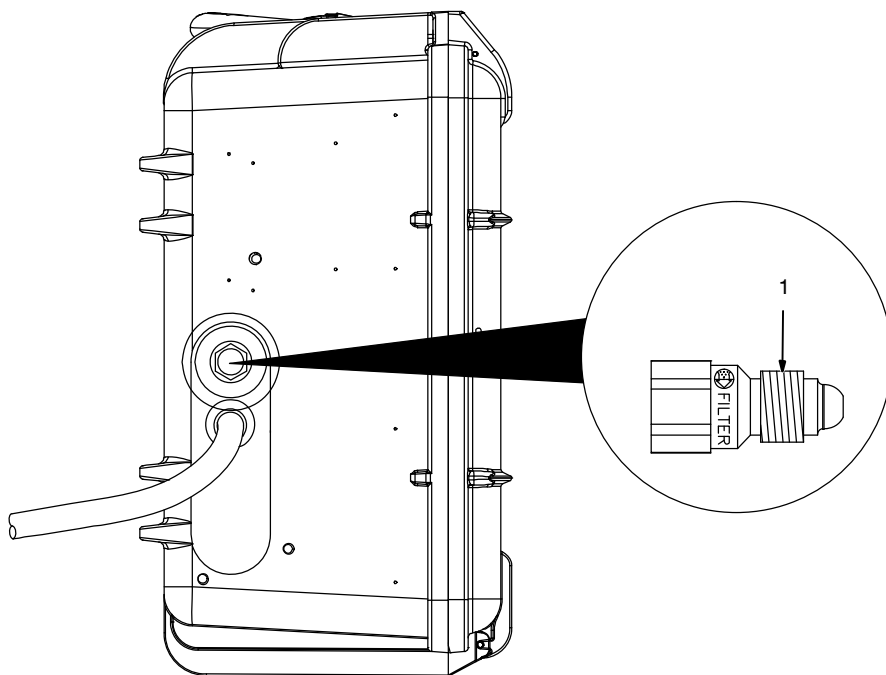

Tools Needed:



3/4 in.

256 623-A

## 7-4. Troubleshooting

			
Trouble	Remedy		
Wire does not feed; open-circuit voltage available.	Check power switch S1 and connections, replace if necessary.		
	Check supplementary protector CB1. Reset CB1.		
	Unit overheated. Allow unit to cool.		
	Check sensing lead connection.		
	Check gun trigger plug connection.		
	Check gun trigger. See gun Owner's Manual.		
	Check Resonant Coupler PC23 and connections, replace if necessary.		
	Check DIP switch settings on Meter Board PC22 (see section 5-12)		
	Have Factory Authorized Service Agent check Control board PC1.		
Wire feeds erratically.	Readjust hub tension (see section 5-10).		
	Readjust drive roll pressure (see section 5-10).		
	Clean or replace dirty or worn drive roll (see Section 5-5).		
	Remove weld spatter around nozzle opening.		
	Replace contact tip or liner (see gun Owner's Manual).		
	Change to correct size and type drive roll (see Section 5-5)		
	Check that DIP switches on Motor Control Board (PC 1) are set correctly (see section 5-12)		
	Have Factory Authorized Service Agent check control board PC1.		
Motor runs slowly.	When soft start is on, motor will run slow until weld current is sensed by HD1.		
	Readjust hub tension (see Section 5-10).		
	Check if wire speed dual schedule switch is activated (if applicable, see Section 6-3)		
	Check and replace contact tip or liner if necessary (see gun Owner's Manual).		
	Check that DIP switches on Motor Control Board (PC 1) are set correctly (see section 5-12)		
	Have Factory Authorized Service Agent check Control board PC1.		
Unit does not switch out of Soft Start.	Check transducer HD1 and connections, and replace if necessary.		
Wire feeds when Jog switch is pressed but not when gun trigger is pressed.	Check gun trigger connection at wire feeder. Check gun trigger leads and trigger switch. See gun Owner's Manual.		
	Check DIP switch settings on Meter Board PC22 (see section 5-12)		
Wire feeds when Jog switch is pressed but not when gun trigger is pressed.	Have Factory Authorized Service Agent check Control board PC1.		
Wire stubbing on low end using a constant current power source or feeder resets.	Ensure that CC/CV switch in feeder is in CC position (see Section 6-1).		
	Increase power source inductance setting if available.		
	Increase output setting of power source or decrease wire feed speed.		
Gas does not flow or does not stop flowing; wire feeds.	Clear blockage in gas hose or replace hose.		
	Clear blockage in welding gun.		
	Clear blockage in filter (see Section 7-3).		
	Check gas valve.		
	Check coil voltage and connections of gas valve GS1. Check continuity of coil. Replace GS1 if necessary.		
	Have Factory Authorized Service Agent check Control board PC1.		



Trouble	Remedy
Wire remains energized after trigger is released.	Check setting of trigger hold switch.
	Check contactor W1 to see if contacts are frozen closed.
Gun trigger is pressed, gas does not flow, wire is not energized, wire feeds.	If a welding arc is not established in 3 seconds after the gun trigger is activated, the unit will feed wire without energizing the contactor or gas valve. The unit will feed approximately 35 feet (10.7 meters) of wire, then stop feeding. This is to prevent complete despooling of the wire, as in the case of a damaged gun.
Display on Meter Board PC22 does not light.	Have Factory Authorized Service Agent check Control board PC1.
	Replace Meter Board PC22.
Segments on Meter Board PC22 are missing.	Replace Meter Board PC22.
Weld voltage on Meter Board PC22 is not accurate.	Weld voltage on Meter Board PC22 will show weld voltage at the feeder. Due to voltage drops in the weld cables, weld voltage at the feeder will not match weld voltage at the welding power source. Due to averaging of weld voltage, if weld time is less than 8 seconds the displayed weld voltage at the feeder may not be accurate.
	Check Motor Control PC1 and connections, replace if necessary.
While not welding – Voltage display shows three dashes.	This is normal when unit is connected to a Non–ArcReach compatible power source (see Section 6-1).
	Unit is connected to but not associated to an ArcReach control or ArcReach compatible power source (see Section 5-4).
While not welding – Voltage display shows CC.	This is normal when the CC/CV switch is set to CC mode (see Section 6-1).
Weld amperage on Meter Board PC22 is not accurate.	Amperage displayed at feeder is approximate. Refer to power source for actual amperage (see Section 5-12)
	Check DIP switch settings on Meter Board PC22 (see Section 5-12).
	Check transducer HD1 and connections, and replace if necessary.
	Check Motor Control PC1 and connections, replace if necessary.
Software and weld time information on Meter Board PC22 is not accurate.	Check DIP switch settings on Meter Board PC22 (see Section 5-12).
	Check Motor Control PC1 and connections, replace if necessary.
When associated to an ArcReach control or ArcReach compatible power source – Voltage displayed on feeder does not match voltage on power source.	Preset voltages between the feeder and welding power source should be within 0.5 volt of each other.
	When associated to an ArcReach control, verify that the ArcReach control is configured properly (see ArcReach control owner's manual).
	While welding the voltage displayed at the feeder is the weld voltage at the feeder. The voltage displayed at the power source is the weld voltage at the power source. These two voltages will not match due to voltage drops in the weld cables.
	Due to averaging of the weld voltage, if weld time is less than 8 seconds the displayed weld voltage at the feeder may not be accurate.
	Check Motor Control PC1 and connections, replace if necessary.
Feeder will not associate to an ArcReach control or ArcReach compatible power source.	Follow associating wire feeder procedure (see Section 5-3).
	CC/CV switch must be set to CV to associate to ArcReach control or ArcReach compatible power source (see Section 6-1)
	Ensure that the ArcReach compatible power source Mode Switch is set correctly, see welding power source Owner's Manual.



# SECTION 8 - ELECTRICAL DIAGRAM

**⚠ WARNING**

- Do not touch live electrical parts.
- Disconnect input power or stop engine before servicing.
- Do not operate with covers removed.
- Have only qualified persons install, use, or service this unit.

**ELECTRIC SHOCK HAZARD**

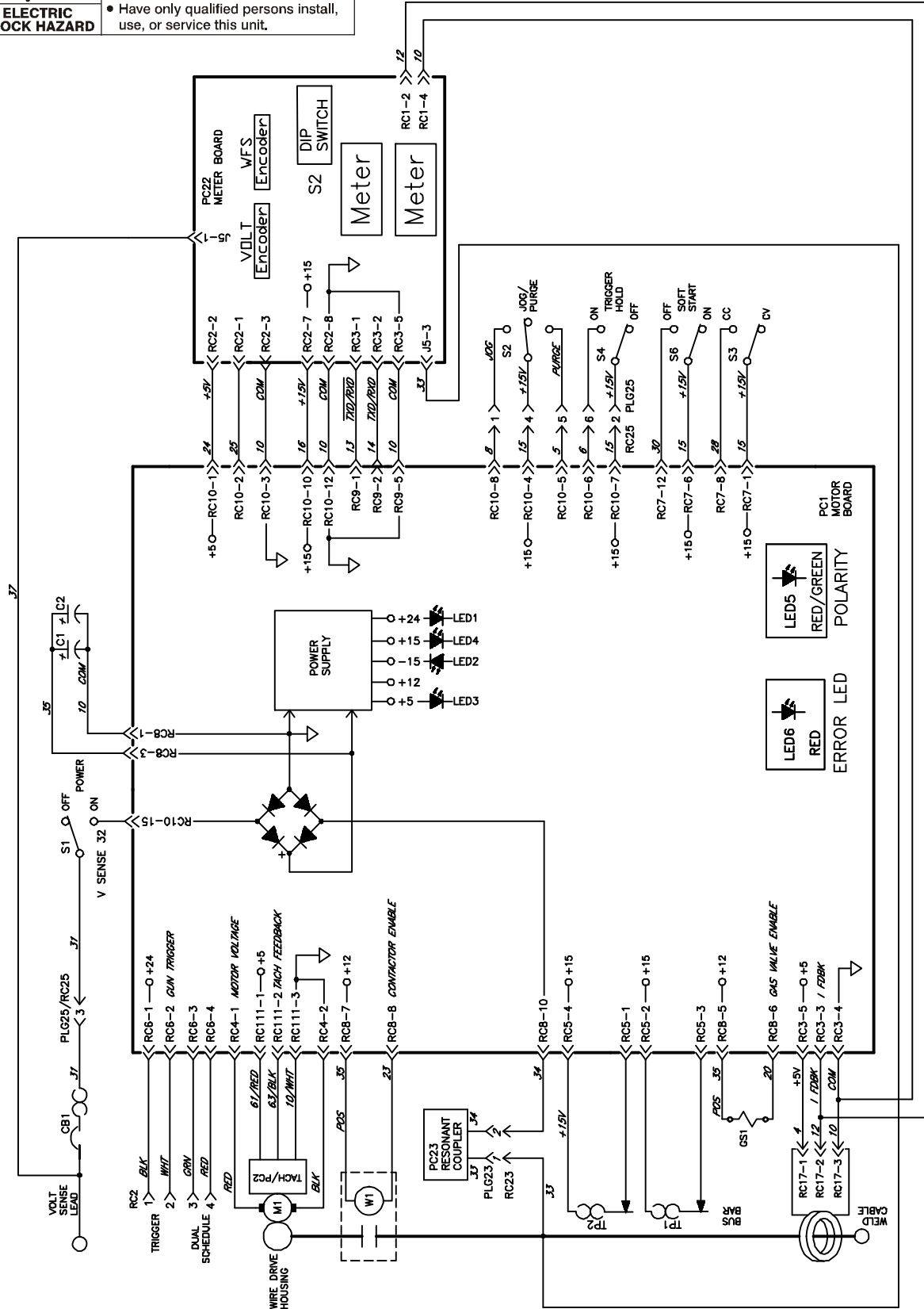

Figure 8-1. Circuit Diagram For Wire Feeder

# SECTION 9 – PARTS LIST

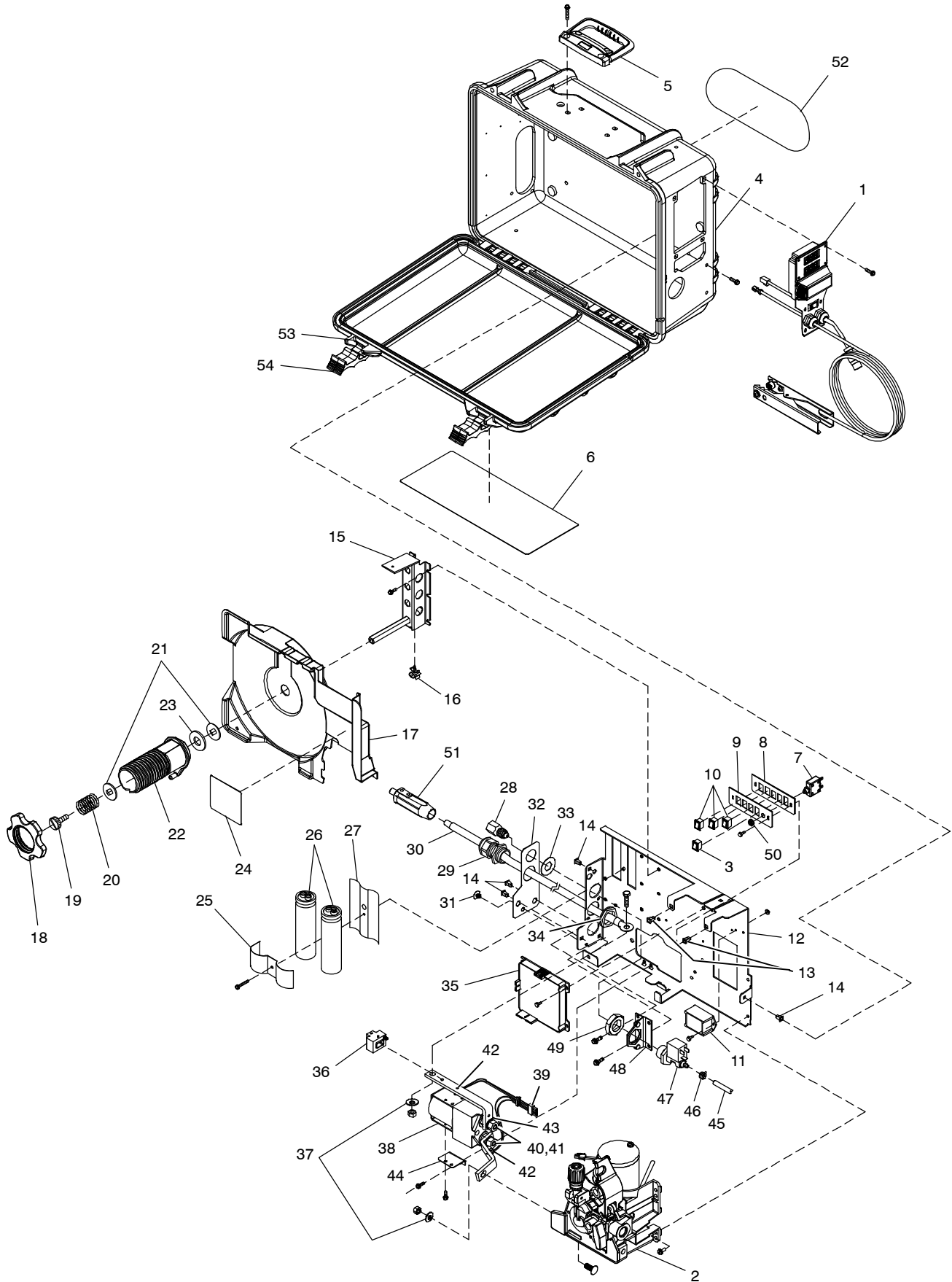

Figure 9-1. Complete Assembly

278813-B

Item No.	Diagram marking	Part No.	Description	Quantity
----------	-----------------	----------	-------------	----------

**Figure 9-1. Complete Assembly**

1		Fig 9-2	Panel Assembly Front	1
2		Fig 9-3	Drive Assembly, Wire	1
3	S2	266614	Switch, Rocker Spdt 8A 125VAC (On)-Off-(On) .187T	1
4		258330	Case, Feeder Machined Blk W/Inserts 12VS ArcReach	1
5		208015	Handle, Rubberized Carrying	1
6		279633	Label, Warning/Miller ArcReach SuitCase 12 Side	1
7	CB1	083432	Supplementary Pro, Man Reset 1P 10A 250VAC Frict	1
8		255703	Panel, Inner SCII Std Breaker	1
9		257773	Plate, Inner ArcReach Standard Breaker	1
10	S3, S4, S6	217932	Switch, Rocker Spst .4VA 28VDC On-None-Off .187 Ter	3
11	PC23	257190	Module, ArcReach Series Resonant L-C Coupler	1
12		252177	Chassis, Control Box	1
13		256594	Grommet, Scr No 8/10 Panel Hole .309x.315 .125H	2
14		256595	Grommet, Scr No 8/10 Panel Hole .270x.290 .062H	5
15		222103	Support, Spool	1
16		222294	Clip, Wire/Cord .380 Bundle .250Hole .105 Thk Blk	2
17		252186	Shroud, Wire	1
18		235607	Nut, Hub	1
19		237843	Knob, Brake Adjust	1
20		172918	Spring	1
21		231211	Washer, Anti-Turn	2
22		235608	Hub, Spool 12 Inch	1
23		058424	Washer, Fiber (Brake)	1
24		261688	Label, Warning Electric Shock And Pinch Wordless	1
25		210133	Bracket, Capacitor Support SC12	1
26	C1, C2	200606	Capacitor, Elctlt 1200 Uf 300 VDC Can 1.39 Dia	2
27		207678	Insulator, Capacitors	1
28		211989	Fitting, W/Screen	1
29		215980	Bushing, Strain Relief .709/.984 Id x1.375 Mtg Hole	1
30		221346	Weld Cable Assembly, 4/0 (Includes)	1
		600324	Cable, Weld Cop Strd No 4/0 Ep Rubber Jacket 600V	22 in.
		009800	Term, Ring Tng 375 Stud Solistrand 4/0	1
31		259416	Blank, Snap-In Nyl .250 Mtg Hole x.700Hdx.100Hd Ht	1
32		252194	Insulator, Rear Panel	1
33		264929	Bushing Gas Valve Opening HDD	1
34		234126	Nut, Conduit 1.000 Npt Knurled	1
35	PC1	238276	Circuit Card Assy, Motor Control W/Program	1
36	HD1	218339	Transducer, Current 600A Module Supply V +5V	1
37		183387	Washer, Cone .380idx .860odx.109T Stl Pld 4000Lbs	2
38	W1	280844	Contacto Assembly, (Includes)	1
39	PLG5	201665	Housing Plug+Sks, (Service Kit)	1
40		183387	Washer, Cone .380idx .860odx.109T Stl Pld 4000Lbs	2
41		232295	Nut, M10-1.5 17Hex 10H Stl	2
42	TP1, TP2	230471	Thermostat, NC Open 140C Close 110C Snap Action	2
43		253430	Terminal, Connector Friction 0.406 Id	1
44		252252	Bracket, Mtg Contactor	1
45		134834	Hose, SAE .187 Id x .410 Od xCoil	22 in.
46		149332	Clamp, Hose .405 - .485 Clp Dia Slftng Olive Dra	2
47	GS1	226819	Valve, 12VDC 1Way .750-14 Thd 2mm Orf 100PSI	1
48		252254	Bracket, Gas Valve	1
49		220805	Nut, 750-14 Knurled 1.68Dia .41H Nyl	1
50		147195	Nut, 375-27 .54Hex .25H Nyl Flange .62D	1
51		242250	Conn, TW LK Insul Male (Tweco/Lenco Type) HD 3/0-4/0	1
		279671	Label, Warning General Precautionary (EN/FR/SP-SYM)	1
52		279856	Label, Miller 10.000 X 4.227 Horizontal (Wht/Blk)	1
53		219213	Latch, Pin Case	2
54		246485	Latch, Case	2



☞ Hardware is common and not available unless listed.

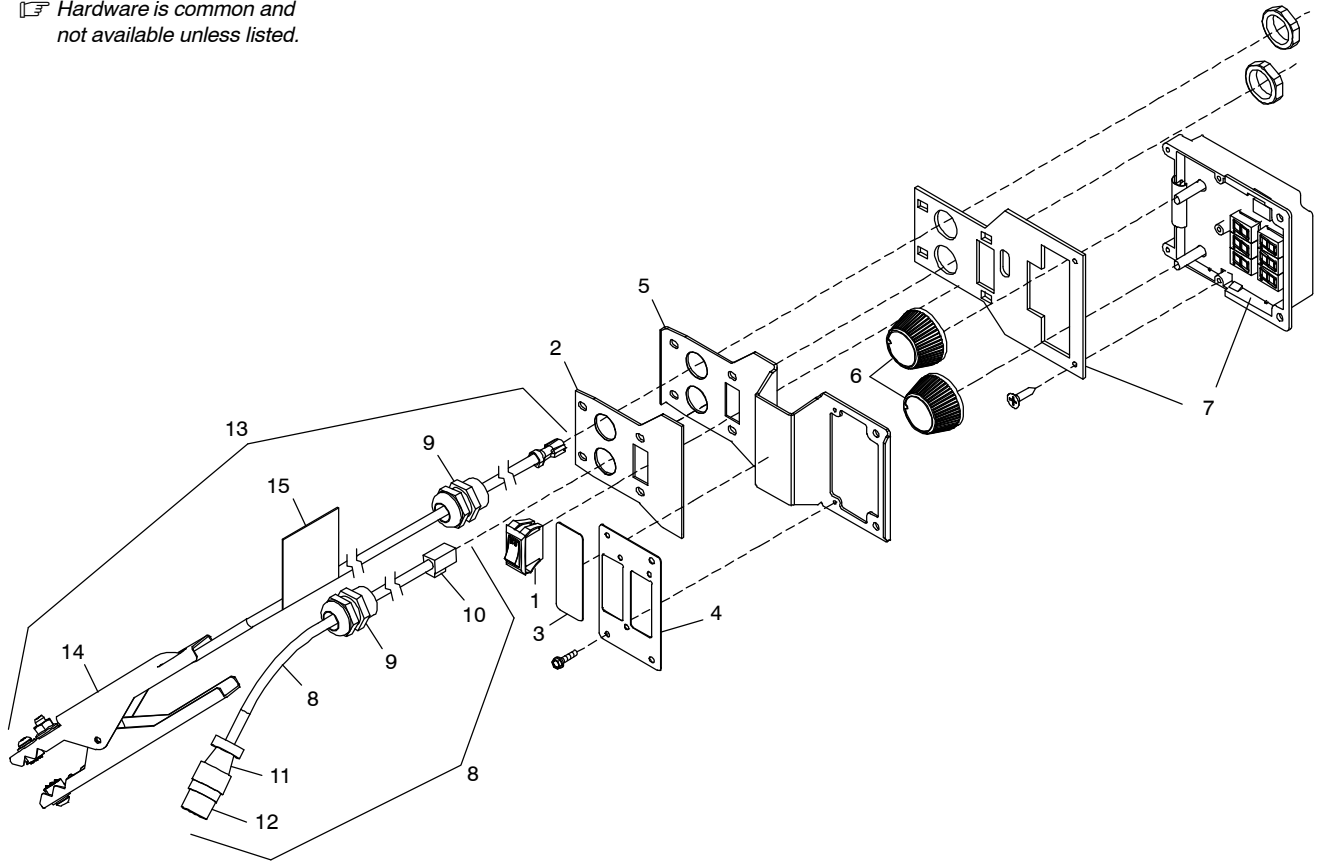

278817-B

**Figure 9-2. Front Panel Assembly with Meters**

Item No.	Dia. Mkgs	Part No.	Description	Quantity
----------	-----------	----------	-------------	----------

**Figure 9-2. Front Panel Assembly with Meters (Figure 9-1 Item 1)**

.. 1	.. S1	.. 267296	.. Switch, Rocker SPST 15A 250VAC On-Off Visi Red Rock	.. 1
.. 2			.. Nameplate, SC ArcReach HDD Lower (Order By Model And Serial Number)	.. 1
.. 3		.. 271367	.. Label, Bezel ArcReach	.. 1
.. 4		.. 277793	.. Lens, Suitcase ArcReach W/Polarity	.. 1
.. 5		.. 257187	.. Panel, Front ArcReach	.. 1
.. 6		.. 277753	.. Knob, Tapered 1.00/1.500 Dia X .90H X .250ID	.. 2
.. 7	.. PC22	.. 276992	.. Circuit Card Assy, Meter ArcReach W/Tray	.. 1
.. 8		.. 252262	.. Cable, Trigger 25 in. W/ Strain Relief (Includes)	.. 1
.. 9		.. 139042	.. Bushing, Strain Relief .270/.470 Id X .804 Mtg Hole	.. 2
.. 10	.. PLG6	.. 115094	.. Housing Plug+Skts, (Service Kit)	.. 1
.. 11		.. 048834	.. Conn, Circ Cpc Clamp Str Rlf Size 11 .329od	.. 1
.. 12	.. RC2	.. 080328	.. Rcpt W/Skts, Free Hanging	.. 1
.. 13		.. 604571	.. Cable, Port No 18 4/C Type Sjo Nprn Jkt Re	.. 25 in.
.. 14		.. 280259	.. Cable, Sensing W/Strain Relief (Includes)	.. 16 Ft
.. 15		.. 280258	.. Clamp, Work 200 Amp	.. 1
.. 16		.. 278752	.. Label, Warning Elec Shock/Volt Sense Clp (Eng/Fr/Sp)	.. 1

**To Maintain The Factory Original Performance Of Your Equipment, Use Only Manufacturer'S Suggested Replacement Parts. Model And Serial Number Required When Ordering Parts From Your Local Distributor.**

☞ Hardware is common and not available unless listed.

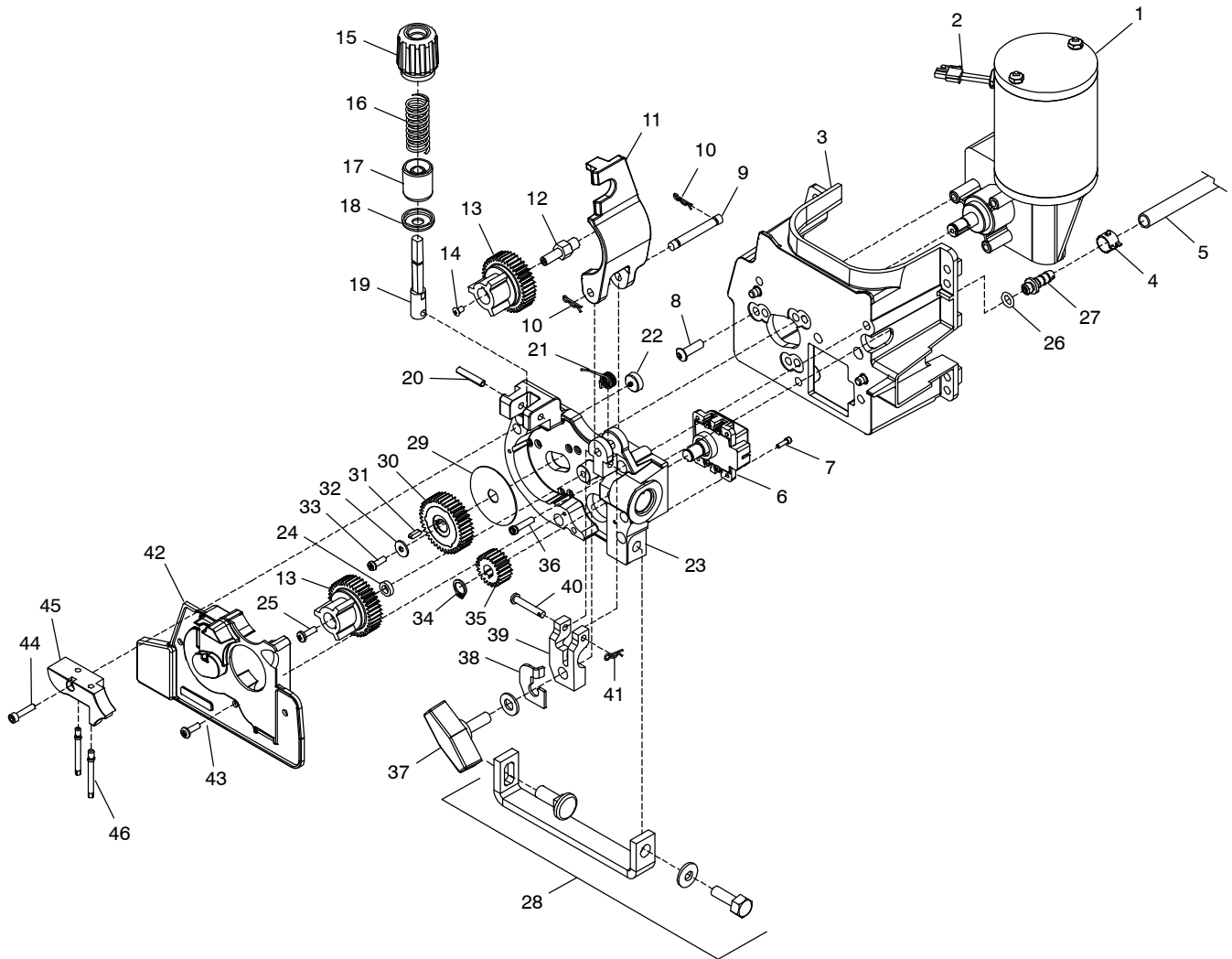

257 016-B

Figure 9-3. Drive Assembly, Wire



Item No.	Dia. Mkgs	Part No.	Description	Quantity
<b>Figure 9-3. Drive Assembly, Wire (Figure 9-1 Item 2)</b>				
1	M1	252214	Motor, Right Angle 24VDC	1
2	PLG4	131054	Housing Plug+Skts, (Service Kit)	1
3		252229	Insulator, Motor/Drive/Tach	1
4		149332	Clamp, Hose .405 – .485 Clp Dia Slftng Olive Dra	1
5		134834	Hose, SAE .187 Id x .410 Od xcoil	22 In.
6		263858	Module, Tach Service	1
7		231181	Screw, 004–40x .37 Soc Hd–Hex Stl Pld	4
8		174610	Screw, M 6–1.0x 20 Soc Hd Button Cap Blk	3
		256035	Casting Assembly, Drive (Includes)	1
9		079634	Pin, Hinge	1
10		151828	Pin, Cotter Hair .042 x .750	3
11		252235	Lever, Mtg Pressure Gear Machined	1
12		252238	Stand–Off, Drive Roll Carrier	1
13		172075	Carrier, Drive Roll W/Components 24 Pitch	2
14		228562	Screw, 006–32x .25 Pan Hd–Phl W/Ext Washer (Sems) Stl	1
15		196895	Knob, Pressure	1
16		252243	Spring, Cprsn Big	1
17		241856	Cup, Spring	1
18		085244	Washer, Cupped .328idx .812odx16gax.125 Lip	1
19		267899	Fastener, Pinned Machined	1
20		010224	Pin, Spring Cs .187 x 1.000	1
21		222159	Spring, Torsion	1
22		253655	Insulator, Screw Motor	3
23		253513	Housing, Wire Drive	1
24		166072	Spacer, Gear	1
25		273794	Screw, 250–20x1.38 Soc Hd–Hex Gr8 Pln	1
26		264611	O–Ring, .187 Id x .312 Od x .063 Cs 75 Duro Fluor	1
27		144172	Ftg, Hose Brs Barbed M 3/16 TBG x .250-20	1
28		263877	Wire Drive Bus Bar (Service Kit) (Includes)	1
		259857	Screw, 375–16x .87 Hex Hd–Pln Gr5 Pld Blk	1
		231223	Nut, 375–16 .56Hex .34H Stl Pld Clr	1
		183387	Washer, Cone .380idx .860odx.109T Stl Pld 4000lbs	2
		252232	Bolt, Crg Stl .375–16 x 1.000 Gr5 Pl Fnsh	1
29		252230	Grommet, Motor Shaft	1
30		252786	Drive, Pinion 10mm Shaft	1
31		252220	Key, Stl 3mm/3mm x 10mm	1
32		602237	Washer, Flat .172idx0.500od x .048t Stl Pld Blk	1
33		174609	Screw, M 4– .7x 12 Cheese Hd Blk Din 84	1
34		133308	Ring, Rtnng Ext .375 Shaft x .025 Thk	1
35		168825	Drive, Pinion Sntr 22T 24P .376 Bore	1
36		252222	Screw, 010–32x .75 Soc Hd–Hex Stl Gr8 Pld Lkg Patch	4
37		124778	Knob, T 2.000 Bar W/.312-18 Stud 1.000 Lg Plstc	1
38		237188	Lock, Pin Power	1
39		278295	Clamp, Power Pin Cast	1
40		234073	Pin, Hinge	1
41		151828	Pin, Cotter Hair .042 x .750	3
42		252785	Cover, Gear	1
43		258838	Screw, 008–32x .37 Pan Hd–Phl Stl Pld Zc Lkg Patch	3
44		604432	Screw, 008–32x 1.00 Soc Hd–Hex Gr8 Pln	1
45		252322	Block, Wire Inlet Guide	1
46		252323	Pin, Wire Inlet Guide	2

**To Maintain The Factory Original Performance Of Your Equipment, Use Only Manufacturer’S Suggested Replacement Parts. Model And Serial Number Required When Ordering Parts From Your Local Distributor.**

**Table 9-1. Drive Roll**

☞ Base Selection Of Drive Rolls Upon The Following Recommended Usages:

1. V-Grooved Rolls For Hard Wire.
2. U-Grooved Rolls For Soft And Soft Shelled Cored Wires.
3. U-Cogged Rolls For Extremely Soft Shelled Wires (Usually Hard Surfacing Types).
4. V-Knurled Rolls For Hard Shelled Cored Wires.
5. Drive Roll Types May Be Mixed To Suit Particular Requirements (Example: V-Knurled Roll In Combination With U-Grooved).

Wire Diameter			Drive Roll (2 Required)	
Fraction	Decimal	Metric	Part No.	Type
0.023–0.025 in.	0.023–0.025 in.	0.6 mm	087130	V–Grooved
0.030 in.	0.030 in.	0.8 mm	053695	V–Grooved
0.035 in.	0.035 in.	0.9 mm	053700	V–Grooved
0.040 in.	0.040 in.	1.0 mm	053696	V–Grooved
0.045 in.	0.045 in.	1.2 mm	053697	V–Grooved
0.052 in.	0.052 in.	1.3 mm	053698	V–Grooved
1/16 in.	0.062 in.	1.6 mm	053699	V–Grooved
0.035 in.	0.035 in.	0.9 mm	072000	U–Grooved
0.045 in.	0.045 in.	1.2 mm	053701	U–Grooved
0.052 in.	0.052 in.	1.3 mm	053702	U–Grooved
1/16 in.	0.062 in.	1.6 mm	053706	U–Grooved
5/64 in.	0.079 in.	2.0 mm	053704	U–Grooved
0.035 in.	0.035 in.	0.9 mm	132958	V–Knurled
0.045 in.	0.045 in.	1.2 mm	132957	V–Knurled
0.052 in.	0.052 in.	1.3 mm	132956	V–Knurled
1/16 in.	0.062 in.	1.6 mm	132955	V–Knurled
0.068–0.072 in.	0.068–0.072 in.	1.8 mm	132959	V–Knurled
0.079 in.	0.079 in.	2.0 mm	132960	V–Knurled
0.045 in.	0.045 in.	1.2 mm	083489	U–Cogged
0.052 in.	0.052 in.	1.3 mm	083490	U–Cogged
1/16 in.	0.062 in.	1.6 mm	053708	U–Cogged
5/64 in.	0.079 in.	2.0 mm	053710	U–Cogged

S-0859

# SECTION 10 – OPEN SOURCE LICENSE NOTICES

---

**KSDK CMSIS Peripheral Drivers** –Open source – Apache 2.0 & BSD–3–Clause, by Freescale

\*BSD–3–Clause

Copyright (c) 2015–2016, Freescale Semiconductor, Inc.

All rights reserved.

Redistribution and use in source and binary forms, with or without modification, are permitted provided that the following conditions are met:

Redistributions of source code must retain the above copyright notice, this list of conditions and the following disclaimer.

Redistributions in binary form must reproduce the above copyright notice, this list of conditions and the following disclaimer in the documentation and/or other materials provided with the distribution.

Neither the name of Freescale Semiconductor, Inc. nor the names of its contributors may be used to endorse or promote products derived from this software without specific prior written permission.

THIS SOFTWARE IS PROVIDED BY THE COPYRIGHT HOLDERS AND CONTRIBUTORS "AS IS" AND ANY EXPRESS OR IMPLIED WARRANTIES, INCLUDING, BUT NOT LIMITED TO, THE IMPLIED WARRANTIES OF MERCHANTABILITY AND FITNESS FOR A PARTICULAR PURPOSE ARE DISCLAIMED. IN NO EVENT SHALL THE COPYRIGHT HOLDER OR CONTRIBUTORS BE LIABLE FOR ANY DIRECT, INDIRECT, INCIDENTAL, SPECIAL, EXEMPLARY, OR CONSEQUENTIAL DAMAGES (INCLUDING, BUT NOT LIMITED TO, PROCUREMENT OF SUBSTITUTE GOODS OR SERVICES; LOSS OF USE, DATA, OR PROFITS; OR BUSINESS INTERRUPTION) HOWEVER CAUSED AND ON ANY THEORY OF LIABILITY, WHETHER IN CONTRACT, STRICT LIABILITY, OR TORT (INCLUDING NEGLIGENCE OR OTHERWISE) ARISING IN ANY WAY OUT OF THE USE OF THIS SOFTWARE, EVEN IF ADVISED OF THE POSSIBILITY OF SUCH DAMAGE.

\**Apache 2.0*

Copyright (c) 2009–2015, ARM LIMITED

All rights reserved.

Licensed under the Apache License, Version 2.0 (the "License"); you may not use this file except in compliance with the License.

You may obtain a copy of the License at <http://www.apache.org/licenses/LICENSE-2.0>

Unless required by applicable law or agreed to in writing, software distributed under the License is distributed on an "AS IS" BASIS, WITHOUT WARRANTIES OR CONDITIONS OF ANY KIND, either express or implied.

See the License for the specific language governing permissions and limitations under the License.

**KSDK Peripheral Drivers** – Open source – BSD–3–Clause, by Freescale

Copyright (c) 2015–2016, Freescale Semiconductor, Inc.

All rights reserved.

Redistribution and use in source and binary forms, with or without modification, are permitted provided that the following conditions are met:

Redistributions of source code must retain the above copyright notice, this list of conditions and the following disclaimer.

Redistributions in binary form must reproduce the above copyright notice, this list of conditions and the following disclaimer in the documentation and/or other materials provided with the distribution.

Neither the name of Freescale Semiconductor, Inc. nor the names of its contributors may be used to endorse or promote products derived from this software without specific prior written permission.

THIS SOFTWARE IS PROVIDED BY THE COPYRIGHT HOLDERS AND CONTRIBUTORS "AS IS" AND ANY EXPRESS OR IMPLIED WARRANTIES, INCLUDING, BUT NOT LIMITED TO, THE IMPLIED WARRANTIES OF MERCHANTABILITY AND FITNESS FOR A PARTICULAR PURPOSE ARE DISCLAIMED. IN NO EVENT SHALL THE COPYRIGHT HOLDER OR CONTRIBUTORS BE LIABLE FOR ANY DIRECT, INDIRECT, INCIDENTAL, SPECIAL, EXEMPLARY, OR CONSEQUENTIAL DAMAGES (INCLUDING, BUT NOT LIMITED TO, PROCUREMENT OF SUBSTITUTE GOODS OR SERVICES; LOSS OF USE, DATA, OR PROFITS; OR BUSINESS INTERRUPTION) HOWEVER CAUSED AND ON ANY THEORY OF LIABILITY, WHETHER IN CONTRACT, STRICT LIABILITY, OR TORT (INCLUDING NEGLIGENCE OR OTHERWISE) ARISING IN ANY WAY OUT OF THE USE OF THIS SOFTWARE, EVEN IF ADVISED OF THE POSSIBILITY OF SUCH DAMAGE.

**CMSIS Core header file** – Open source – Apache 2.0

Copyright (c) 2009–2015, ARM LIMITED

All rights reserved.

Licensed under the Apache License, Version 2.0 (the "License"); you may not use this file except in compliance with the License.

You may obtain a copy of the License at <http://www.apache.org/licenses/LICENSE-2.0>

Unless required by applicable law or agreed to in writing, software distributed under the License is distributed on an "AS IS" BASIS, WITHOUT WARRANTIES OR CONDITIONS OF ANY KIND, either express or implied.

See the License for the specific language governing permissions and limitations under the License.

**USB** – Open source – BSD-3-Clause, by Freescale

Copyright (c) 2015, Freescale Semiconductor, Inc.

All rights reserved.

Redistribution and use in source and binary forms, with or without modification, are permitted provided that the following conditions are met:

Redistributions of source code must retain the above copyright notice, this list of conditions and the following disclaimer.

Redistributions in binary form must reproduce the above copyright notice, this list of conditions and the following disclaimer in the documentation and/or other materials provided with the distribution.

Neither the name of Freescale Semiconductor, Inc. nor the names of its contributors may be used to endorse or promote products derived from this software without specific prior written permission.

THIS SOFTWARE IS PROVIDED BY THE COPYRIGHT HOLDERS AND CONTRIBUTORS "AS IS" AND ANY EXPRESS OR IMPLIED WARRANTIES, INCLUDING, BUT NOT LIMITED TO, THE IMPLIED WARRANTIES OF MERCHANTABILITY AND FITNESS FOR A PARTICULAR PURPOSE ARE DISCLAIMED. IN NO EVENT SHALL THE COPYRIGHT HOLDER OR CONTRIBUTORS BE LIABLE FOR ANY DIRECT, INDIRECT, INCIDENTAL, SPECIAL, EXEMPLARY, OR CONSEQUENTIAL DAMAGES (INCLUDING, BUT NOT LIMITED TO, PROCUREMENT OF SUBSTITUTE GOODS OR SERVICES; LOSS OF USE, DATA, OR PROFITS; OR BUSINESS INTERRUPTION) HOWEVER CAUSED AND ON ANY THEORY OF LIABILITY, WHETHER IN CONTRACT, STRICT LIABILITY, OR TORT (INCLUDING NEGLIGENCE OR OTHERWISE) ARISING IN ANY WAY OUT OF THE USE OF THIS SOFTWARE, EVEN IF ADVISED OF THE POSSIBILITY OF SUCH DAMAGE.





# TRUE BLUE<sup>®</sup>

## WARRANTY

Effective January 1, 2019

(Equipment with a serial number preface of MK or newer)

This limited warranty supersedes all previous Miller warranties and is exclusive with no other guarantees or warranties expressed or implied.

**LIMITED WARRANTY** – Subject to the terms and conditions below, Miller Electric Mfg. LLC, Appleton, Wisconsin, warrants to authorized distributors that new Miller equipment sold after the effective date of this limited warranty is free of defects in material and workmanship at the time it is shipped by Miller. THIS WARRANTY IS EXPRESSLY IN LIEU OF ALL OTHER WARRANTIES, EXPRESS OR IMPLIED, INCLUDING THE WARRANTIES OF MERCHANTABILITY AND FITNESS.

Within the warranty periods listed below, Miller will repair or replace any warranted parts or components that fail due to such defects in material or workmanship. Miller must be notified in writing within thirty (30) days of such defect or failure, at which time Miller will provide instructions on the warranty claim procedures to be followed. Notifications submitted as online warranty claims must provide detailed descriptions of the fault and troubleshooting steps taken to diagnose failed parts. Warranty claims that lack the required information as defined in the Miller Service Operation Guide (SOG) may be denied by Miller.

Miller shall honor warranty claims on warranted equipment listed below in the event of a defect within the warranty coverage time periods listed below. Warranty time periods start on the delivery date of the equipment to the end-user purchaser, or 12 months after the equipment is shipped to a North American distributor, or 18 months after the equipment is shipped to an international distributor, whichever occurs first.

1. 5 Years Parts — 3 Years Labor
  - \* Original Main Power Rectifiers Only to Include SCRs, Diodes, and Discrete Rectifier Modules
2. 3 Years — Parts and Labor Unless Specified
  - \* Auto-Darkening Helmet Lenses (No Labor) (See Classic Series Exception Below)
  - \* Engine Driven Welder/Generators  
**(NOTE: Engines are Warranted Separately by the Engine Manufacturer.)**
  - \* Insight Welding Intelligence Products
  - \* Inverter Power Sources
  - \* Plasma Arc Cutting Power Sources
  - \* Process Controllers
  - \* Semi-Automatic and Automatic Wire Feeders
  - \* Transformer/Rectifier Power Sources
3. 2 Years — Parts and Labor
  - \* Auto-Darkening Helmet Lenses – Classic Series Only (No Labor)
  - \* Auto-Darkening Weld Masks (No Labor)
  - \* Fume Extractors – Capture 5, Filtair 400 and Industrial Collector Series
4. 1 Year — Parts and Labor Unless Specified
  - \* AugmentedArc and LiveArc Welding Systems
  - \* Automatic Motion Devices
  - \* Bernard BTB Air-Cooled MIG Guns (No Labor)
  - \* CoolBelt and CoolBand Blower Unit (No Labor)
  - \* Desiccant Air Dryer System
  - \* Field Options  
**(NOTE: Field options are covered for the remaining warranty period of the product they are installed in, or for a minimum of one year — whichever is greater.)**
  - \* RFCS Foot Controls (Except RFCS-RJ45)
  - \* Fume Extractors – Filtair 130, MWX and SWX Series HF Units
  - \* ICE/XT Plasma Cutting Torches (No Labor)
  - \* Induction Heating Power Sources, Coolers  
**(NOTE: Digital Recorders are Warranted Separately by the Manufacturer.)**
  - \* Load Banks
  - \* Motor-Driven Guns (except Spoolmate Spoolguns)
  - \* PAPR Blower Unit (No Labor)
  - \* Positioners and Controllers
  - \* Racks (For Housing Multiple Power Sources)
  - \* Running Gear/Trailers
  - \* Spot Welders

- \* Subarc Wire Drive Assemblies
  - \* TIG Torches (No Labor)
  - \* Tregaskiss Guns (No Labor)
  - \* Water Cooling Systems
  - \* Wireless Remote Foot/Hand Controls and Receivers
  - \* Work Stations/Weld Tables (No Labor)
5. 6 Months — Parts
    - \* Batteries
  6. 90 Days — Parts
    - \* Accessories (Kits)
    - \* Canvas Covers
    - \* Induction Heating Coils and Blankets, Cables, and Non-Electronic Controls
    - \* M-Guns
    - \* MIG Guns, Subarc (SAW) Torches, and External Cladding Heads
    - \* Remote Controls and RFCS-RJ45
    - \* Replacement Parts (No labor)
    - \* Spoolmate Spoolguns

Miller's True Blue<sup>®</sup> Limited Warranty shall not apply to:

1. **Consumable components; such as contact tips, cutting nozzles, contactors, brushes, relays, work station table tops and welding curtains, or parts that fail due to normal wear. (Exception: brushes and relays are covered on all engine-driven products.)**
2. Items furnished by Miller, but manufactured by others, such as engines or trade accessories. These items are covered by the manufacturer's warranty, if any.
3. Equipment that has been modified by any party other than Miller, or equipment that has been improperly installed, improperly operated or misused based upon industry standards, or equipment which has not had reasonable and necessary maintenance, or equipment which has been used for operation outside of the specifications for the equipment.
4. Defects caused by accident, unauthorized repair, or improper testing.

MILLER PRODUCTS ARE INTENDED FOR COMMERCIAL AND INDUSTRIAL USERS TRAINED AND EXPERIENCED IN THE USE AND MAINTENANCE OF WELDING EQUIPMENT.

The exclusive remedies for warranty claims are, at Miller's option, either: (1) repair; or (2) replacement; or, if approved in writing by Miller, (3) the pre-approved cost of repair or replacement at an authorized Miller service station; or (4) payment of or credit for the purchase price (less reasonable depreciation based upon use). Products may not be returned without Miller's written approval. Return shipment shall be at customer's risk and expense.

The above remedies are F.O.B. Appleton, WI, or Miller's authorized service facility. Transportation and freight are the customer's responsibility. TO THE EXTENT PERMITTED BY LAW, THE REMEDIES HEREIN ARE THE SOLE AND EXCLUSIVE REMEDIES REGARDLESS OF THE LEGAL THEORY. IN NO EVENT SHALL MILLER BE LIABLE FOR DIRECT, INDIRECT, SPECIAL, INCIDENTAL OR CONSEQUENTIAL DAMAGES (INCLUDING LOSS OF PROFIT) REGARDLESS OF THE LEGAL THEORY. ANY WARRANTY NOT PROVIDED HEREIN AND ANY IMPLIED WARRANTY, GUARANTY, OR REPRESENTATION, INCLUDING ANY IMPLIED WARRANTY OF MERCHANTABILITY OR FITNESS FOR PARTICULAR PURPOSE, ARE EXCLUDED AND DISCLAIMED BY MILLER.

Some US states do not allow limiting the duration of an implied warranty or the exclusion of certain damages, so the above limitations may not apply to you. This warranty provides specific legal rights, and other rights may be available depending on your state. In Canada, some provinces provide additional warranties or remedies, and to the extent the law prohibits their waiver, the limitations set out above may not apply. This Limited Warranty provides specific legal rights, and other rights may be available, but may vary by province.

### Warranty Questions?

Call  
1-800-4-A-MILLER  
for your local  
Miller distributor.

Your distributor also gives  
you ...

### Service

You always get the fast,  
reliable response you  
need. Most replacement  
parts can be in your  
hands in 24 hours.

### Support

Need fast answers to the  
tough welding questions?  
Contact your distributor.  
The expertise of the  
distributor and Miller is  
there to help you, every  
step of the way.





# Owner's Record

Please complete and retain with your personal records.

Model Name

Serial/Style Number

Purchase Date

(Date which equipment was delivered to original customer.)

Distributor

Address

City

State

Zip



## For Service

**Contact a DISTRIBUTOR or SERVICE AGENCY near you.**

Always provide Model Name and Serial/Style Number.

Contact your Distributor for:

Welding Supplies and Consumables

Options and Accessories

Personal Safety Equipment

Service and Repair

Replacement Parts

Training (Schools, Videos, Books)

Technical Manuals (Servicing Information and Parts)

Circuit Diagrams

Welding Process Handbooks

To locate a Distributor or Service Agency visit [www.millerwelds.com](http://www.millerwelds.com) or call 1-800-4-A-Miller

Contact the Delivering Carrier to:

File a claim for loss or damage during shipment.

For assistance in filing or settling claims, contact your distributor and/or equipment manufacturer's Transportation Department.

### Miller Electric Mfg. LLC

An Illinois Tool Works Company  
1635 West Spencer Street  
Appleton, WI 54914 USA

### International Headquarters—USA

USA Phone: 920-735-4505 Auto-Attended  
USA & Canada FAX: 920-735-4134  
International FAX: 920-735-4125

For International Locations Visit  
[www.MillerWelds.com](http://www.MillerWelds.com)

